

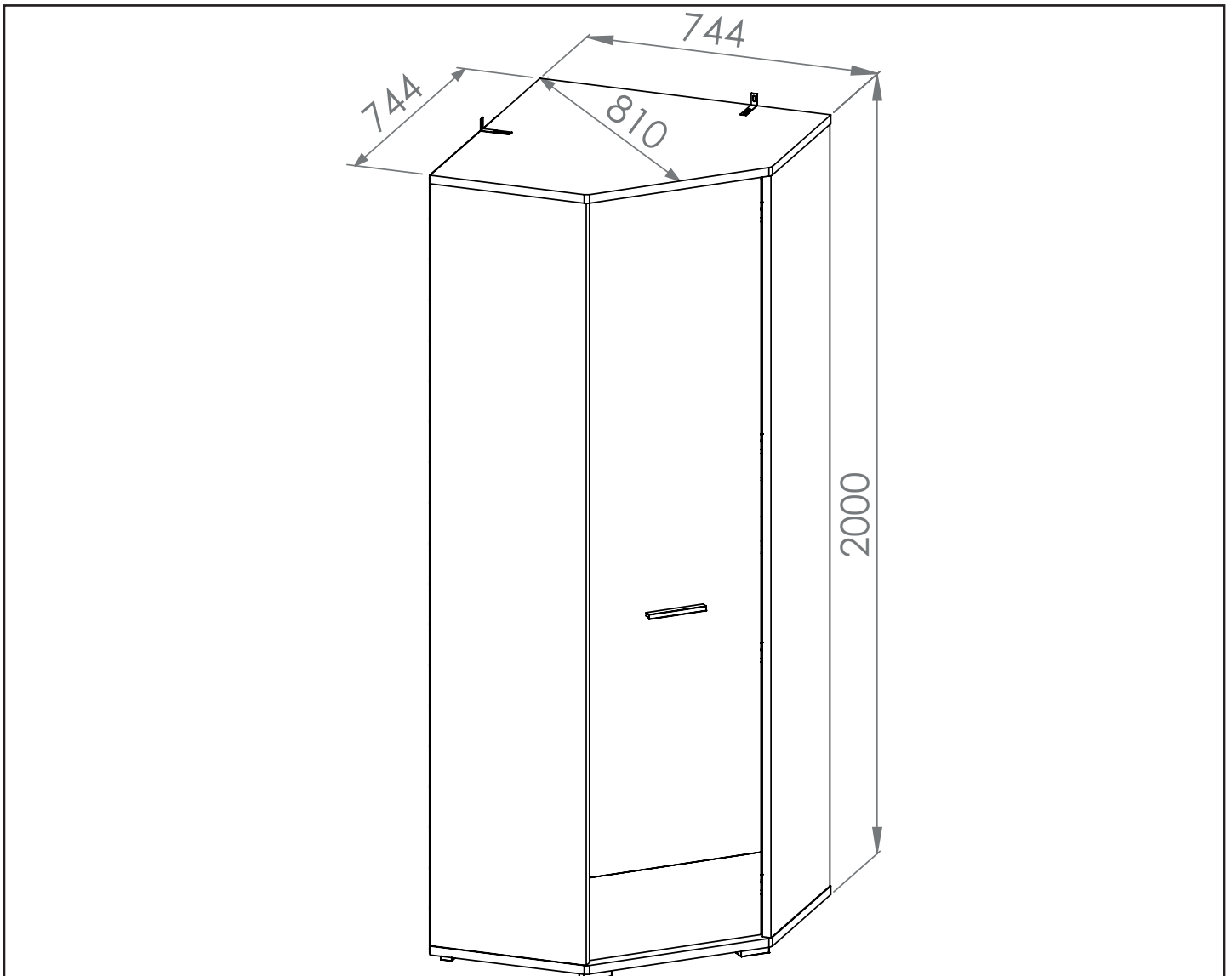





KUBU 13

PL - Instrukcja montażu / BG - Сглобяване инструкция / CZ - Montáž instrukce / DE - Montageanleitung / EN - Assembling instruction / ES - Montaje de instrucciones / EST - Paigaldusjuhend / FR - Notice de montage / HR - Sastavljanje upute / HU - Szerelési utasítás / I - Istruzioni di montaggio / LT - Montavimo instrukcija / LV - Montāžas instrukcija / NL - Montage instructie / P - Montagem de instruções / RO - Asamblarea de instrucțiuni / RU - Сборка инструкция / S - Montering instruktion / SK - Montáž instrukcie / SLO - Sestavljanje navodila / SRB - Склапање инструкцију / TR - Kurulum Talimatları / UKR - Збірка інструкція /

PL - Przed rozpoczęciem zapoznać się z instrukcją montażu / BG - Преди да започнете се отнасят към инструкциите за инсталиране / CZ - Před zahájením naleznete v montážním návodu / DE - Vor die montage, bitte beiliegende anweisungen folgen / EN - Before starting, refer to the assembling advice in annex / ES - Antes de comenzar referirse a las instrucciones de instalación / EST - Enne käivitamist vaadake paigaldusjuhiseid / FR - Avant de commencer, se reporter aux conseils de montage en annexe / HR - Prije početka pogledajte upute za instalaciju / HU - Megkezdése előtt olvassa el a telepítési utasításokat / I - Avanti di cominciare, riportate agli consigli di montaggio / LT - Prieš pradant kreiptis į montavimo instrukcija / LV - Pirms sākt montāžu, iepazīties ar instrukciju / NL - Voordat u begint Zie de installatie-instructies / P - Antes de começar a consultar as instruções de instalação / RO - Înainte de a începe să consultați instrucțiunile de instalare / RU - Перед началом обратитесь к инструкции по установке / S - Innan du börjar se Installationsanvisningen / SK - Pred začatím nájdete v montážnom návode / SLO - Pred začetkom glejte navodila za namestitev / SRB - Пре почетка погледајте упутства за инсталацију / TR - Kurulumla başl madan önce, montaj talimatnamesini sirisiyle takip edin. / UKR - Перед початком зверніться до інструкції з установки /





	CODE				
1	4DRAZ-L697	697		2	2/3
2	KUBU13HDF_02	1976	458	1	1/3
3	KUBU13_06	1936	300	1	2/3
4	KUBU13HDF_01	1976	369	2	1/3
5	KUBU13_02	744	744	1	3/3
6	KUBU13_03	1936	399	1	1/3
7	3LIST_H_L-1934_BIAL	1935		1	1/3
8	KUBU13_08	249	278	4	2/3
9	KUBU13_05	1936	280	1	2/3
10	KUBU13_04	1936	399	1	1/3
11	KUBU13_07	250	279	1	2/3
12	KUBU13_10	1720	454	1	1/3
13	KUBU13_01	744	744	1	3/3
14	KUBU13_11	454	210	1	1/3
15	KUBU13_09	704	92	1	2/3

	CODE				
16					
17					
18					
19					
20					
21					
22					
23					
24					
25					
26					
27					
28					
29					
30					

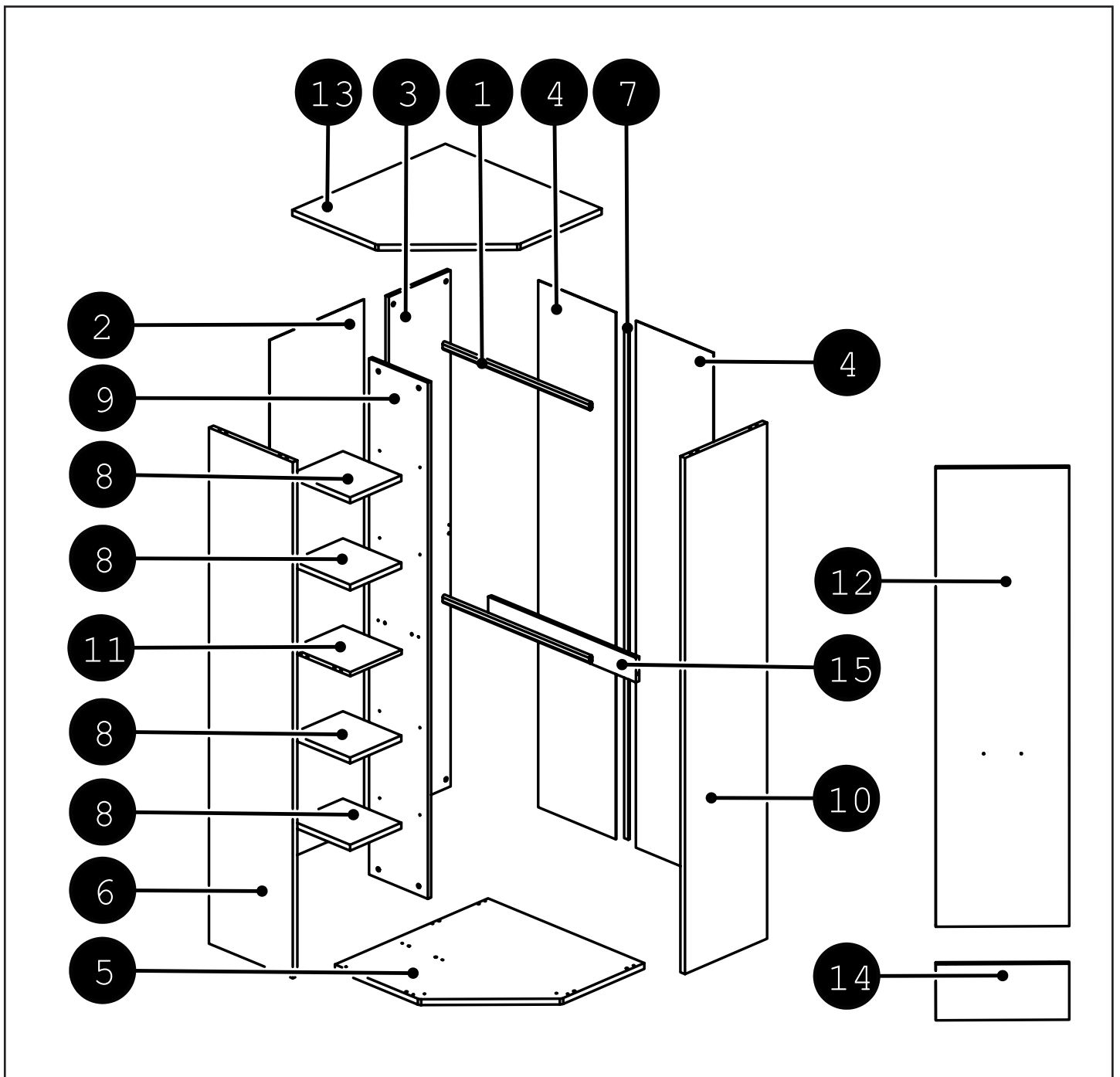

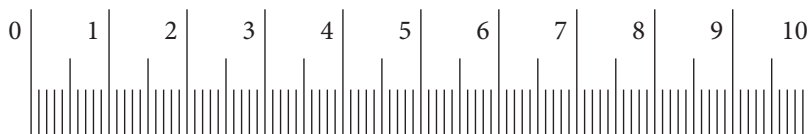
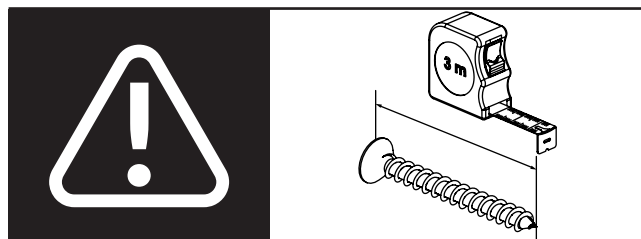
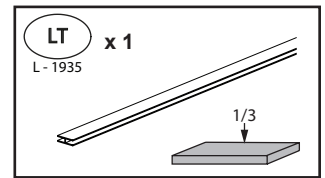
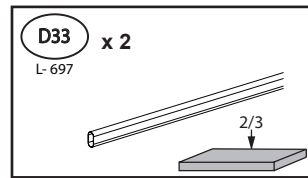
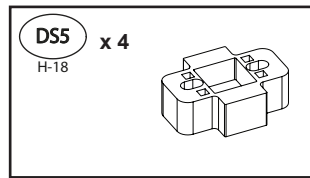
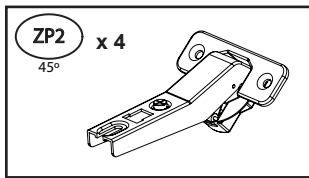
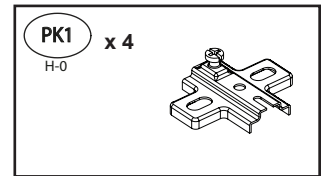
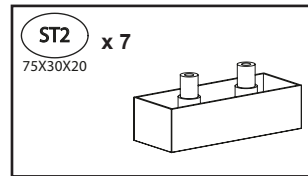
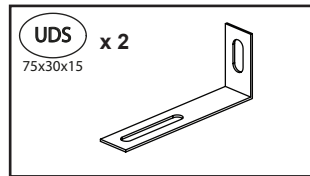
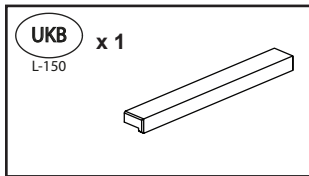
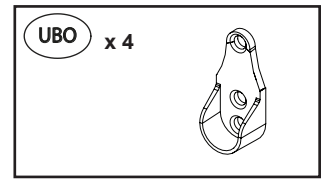
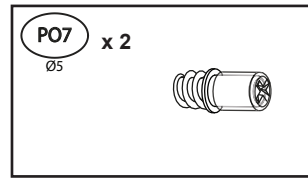
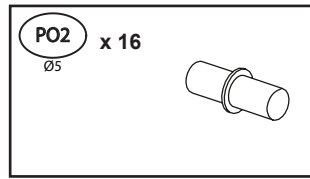
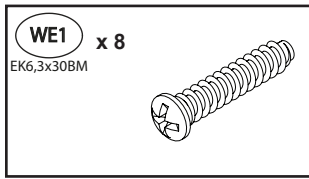
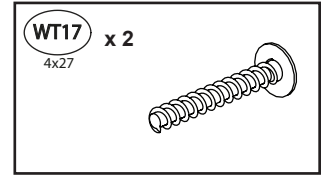
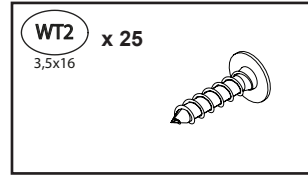
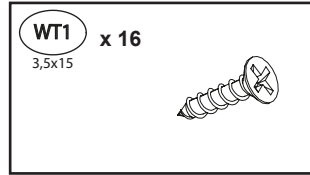
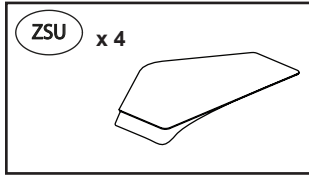
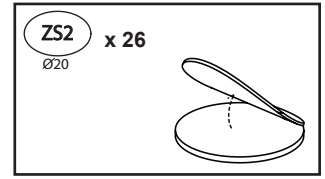
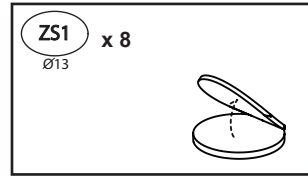
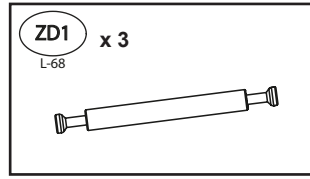
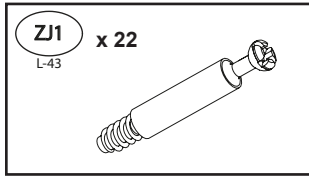
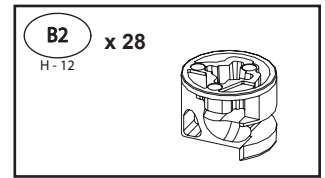
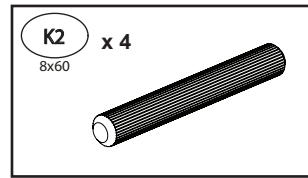
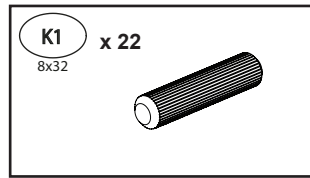
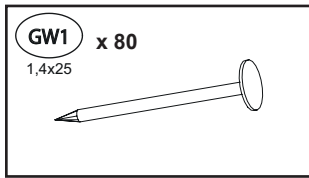

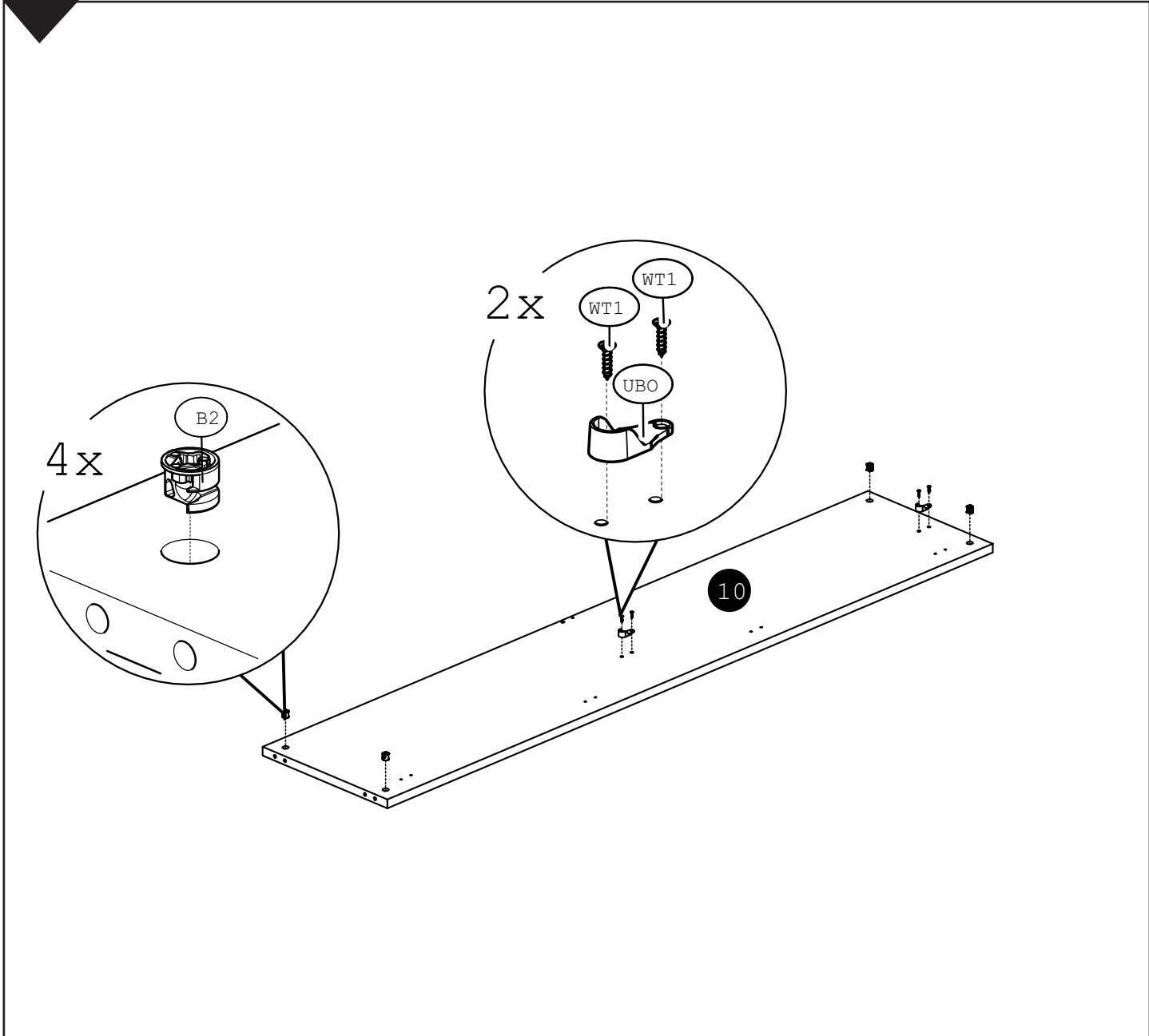
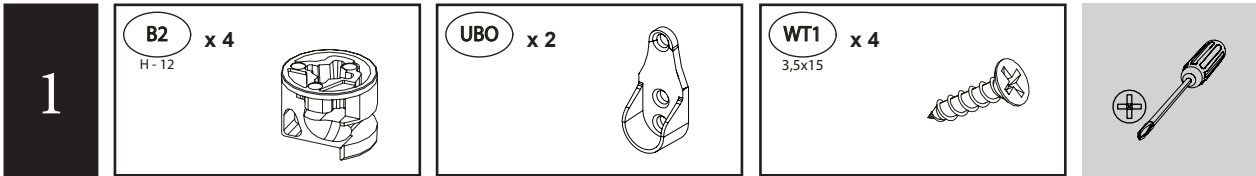
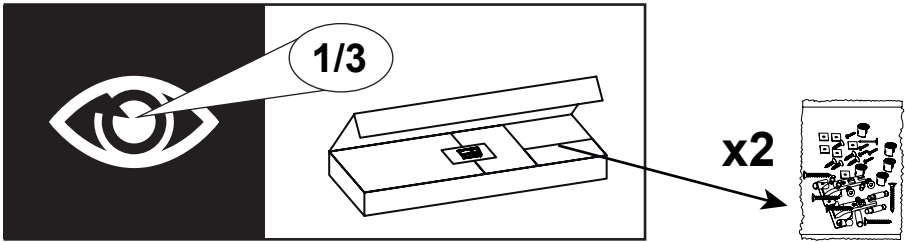

2

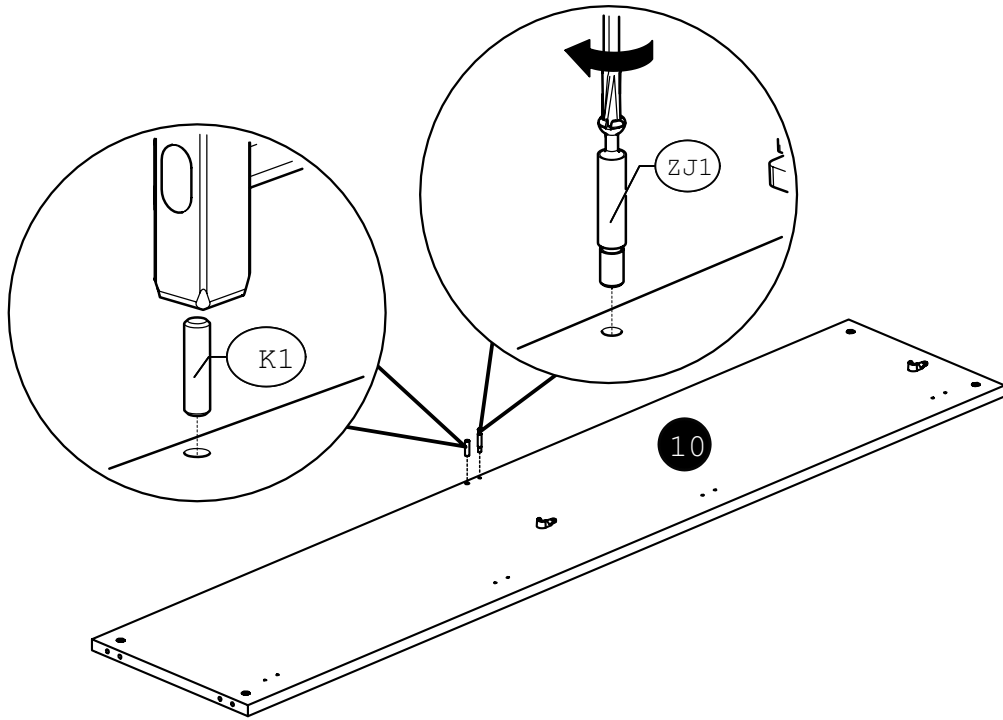
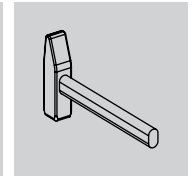
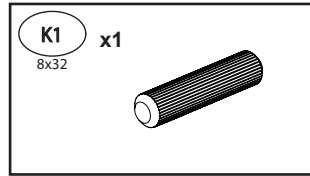
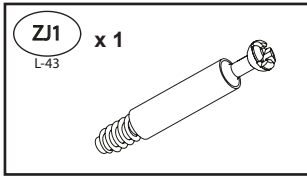

3

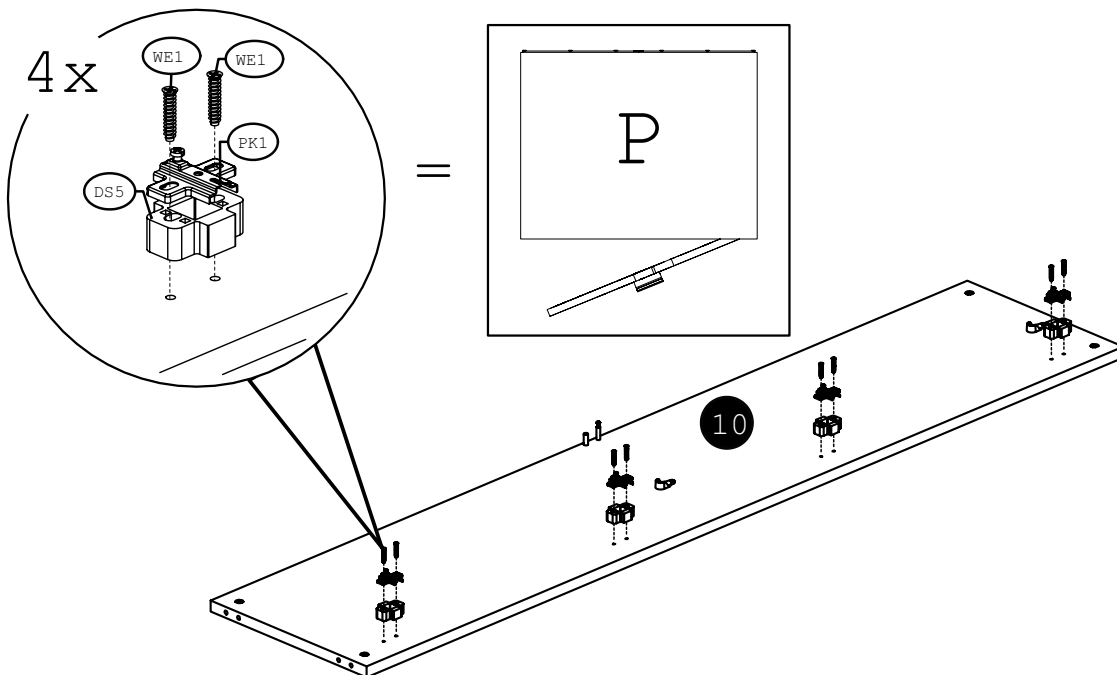
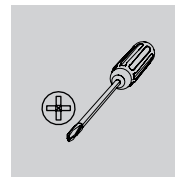
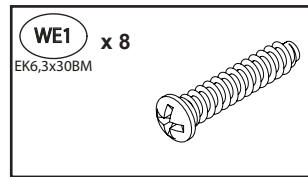
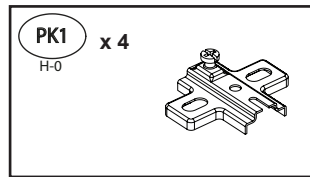
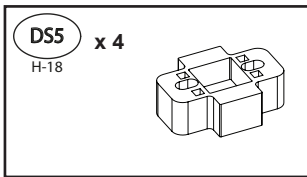

4

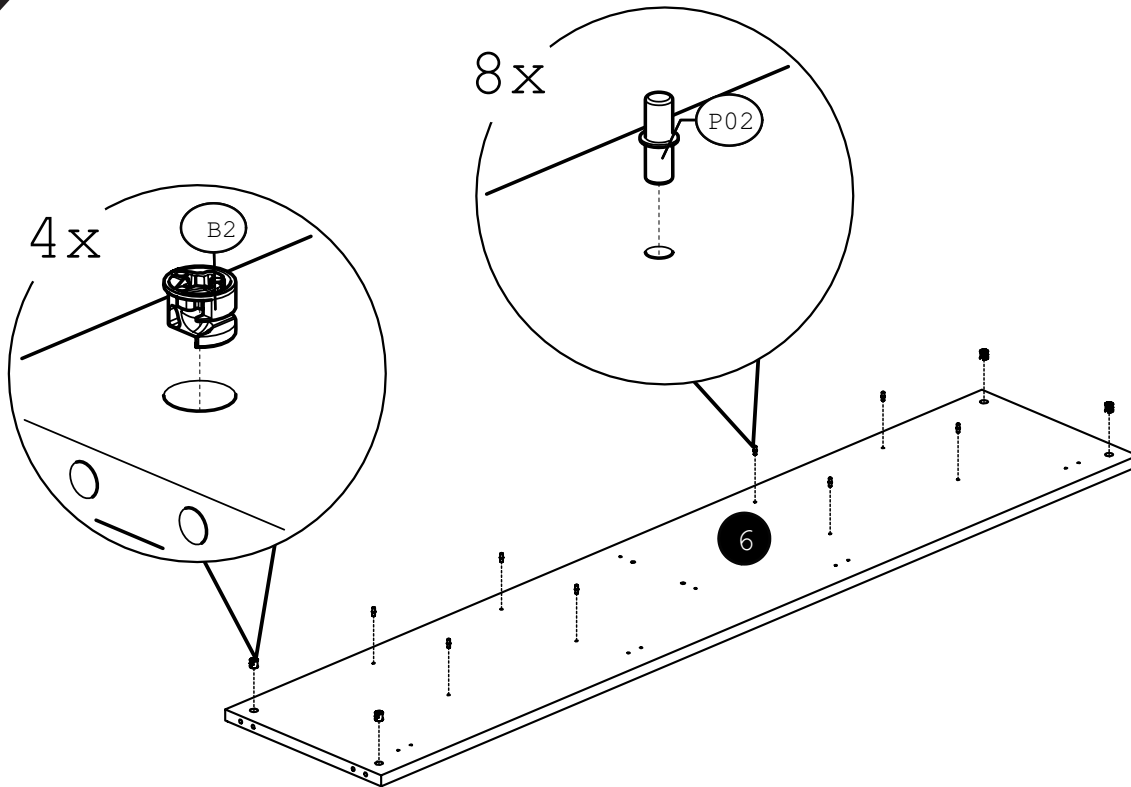
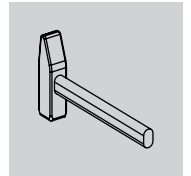
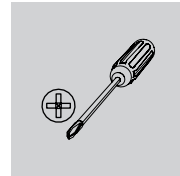
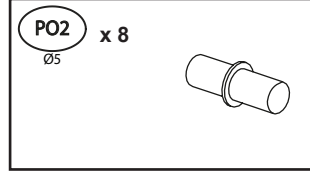
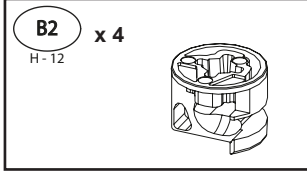

5

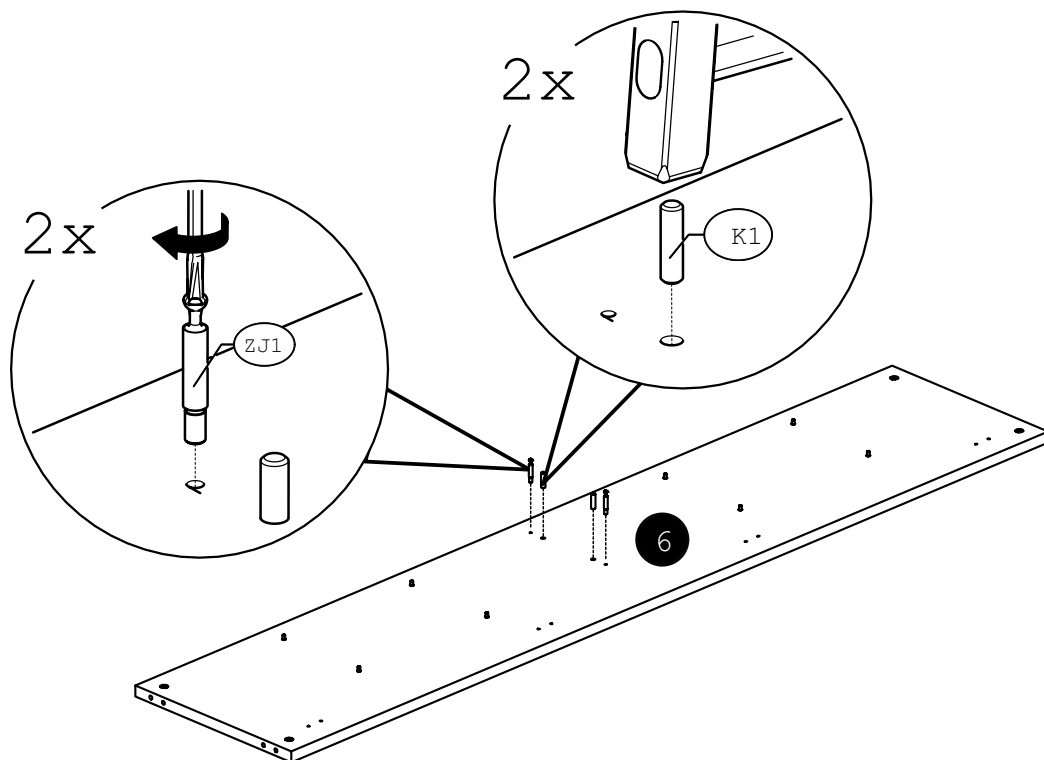
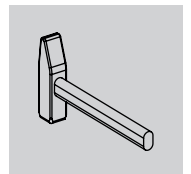
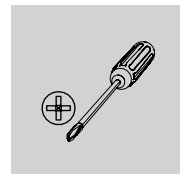
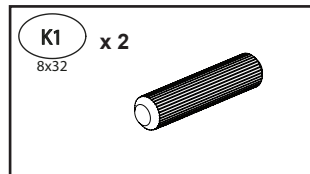
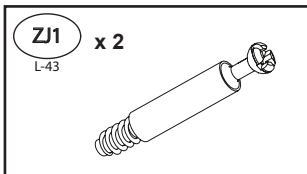

6

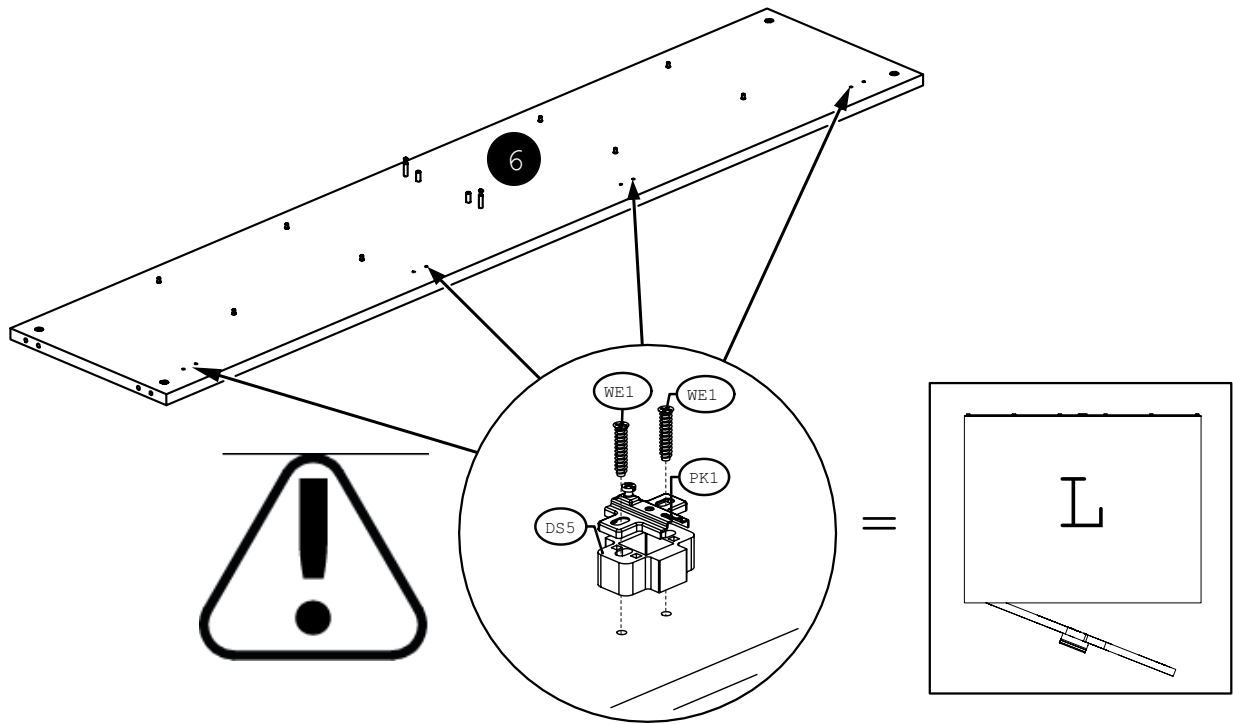

7

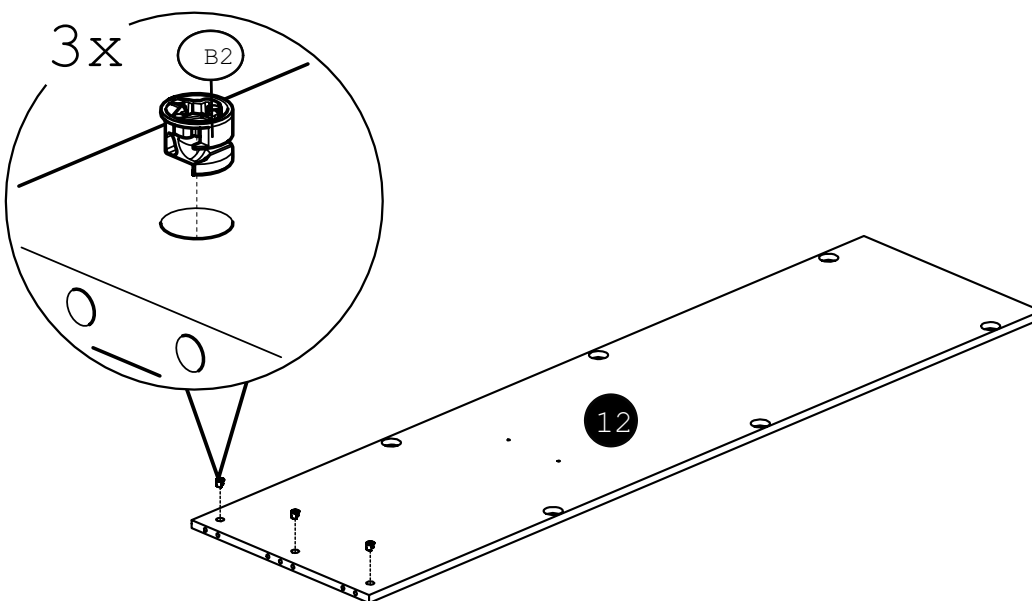
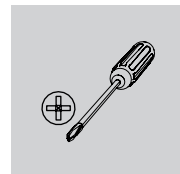
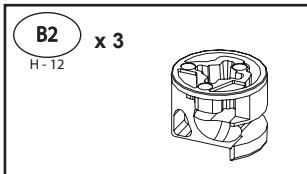

8

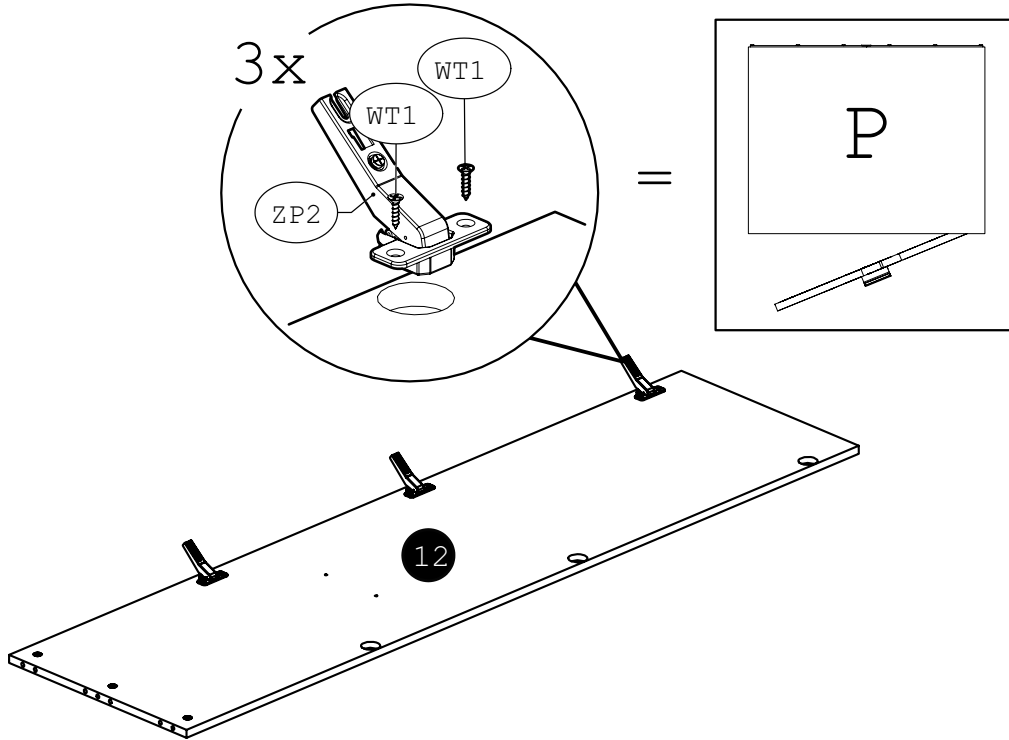
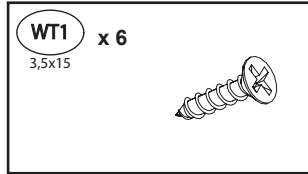
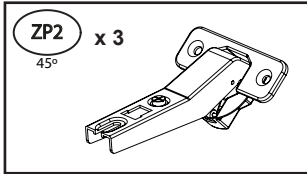

9

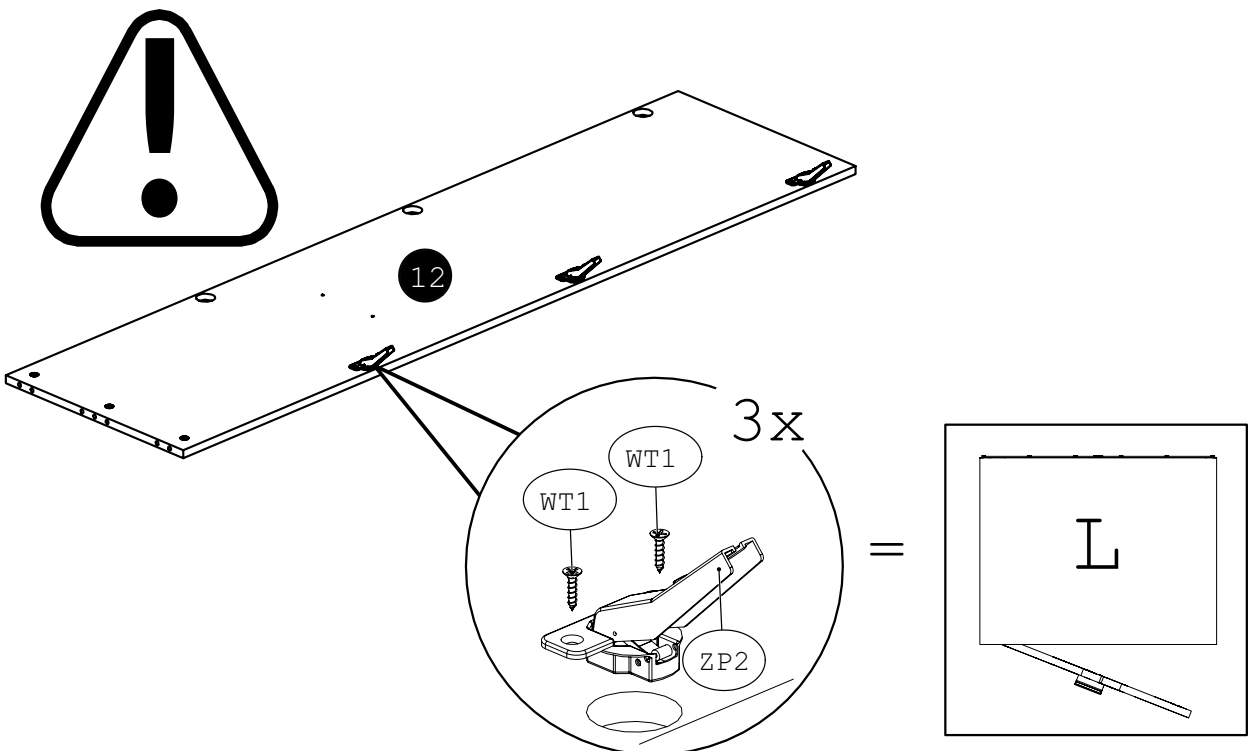

10

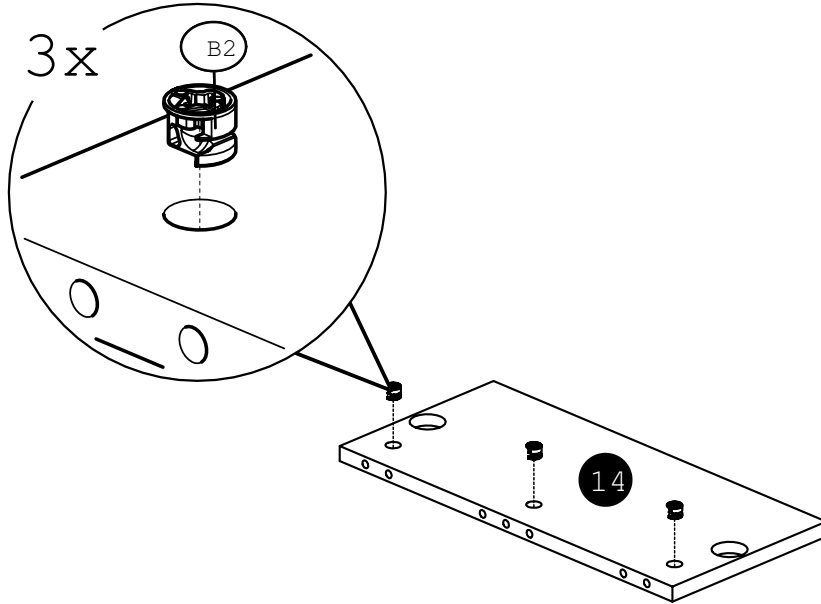
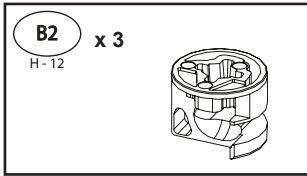

11

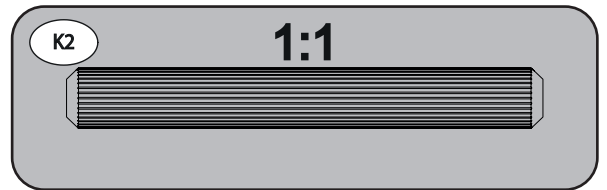
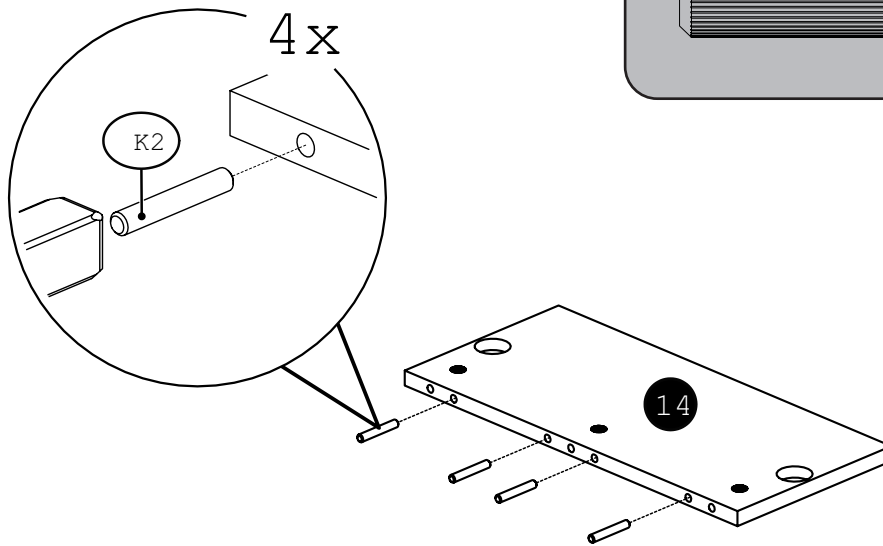
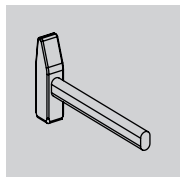
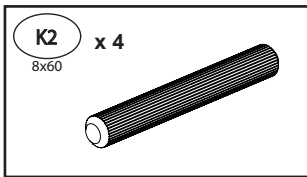

12

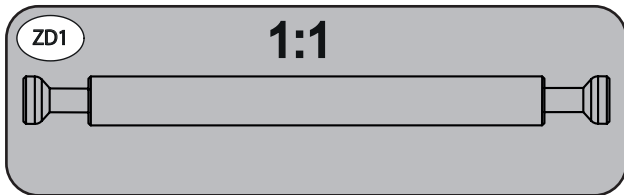
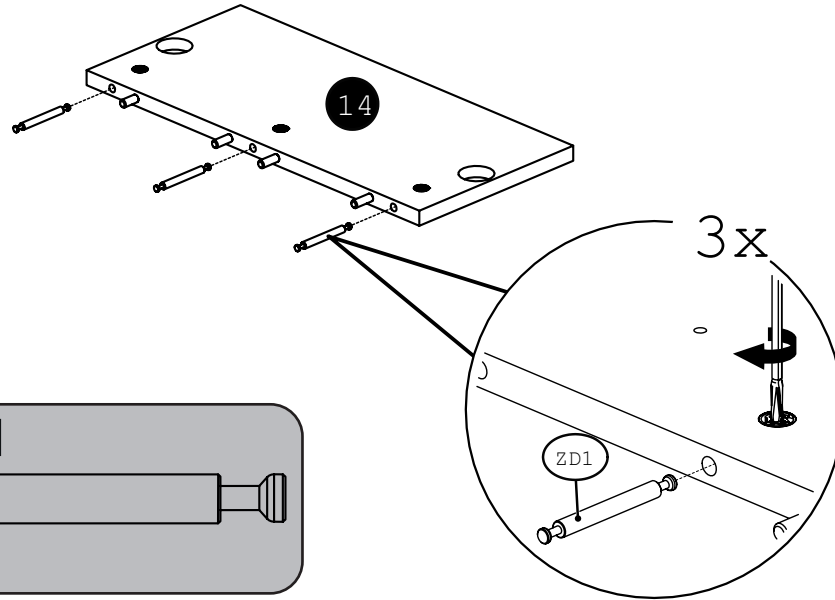
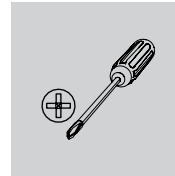
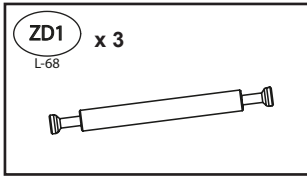

13

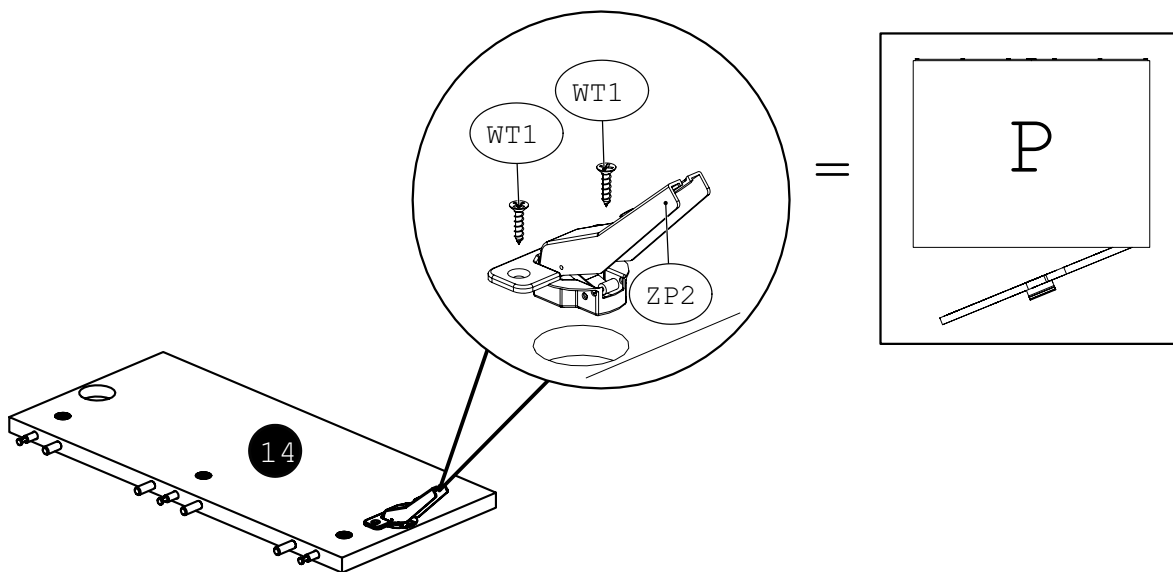
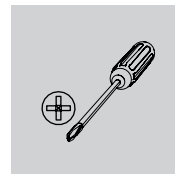
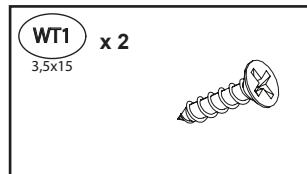
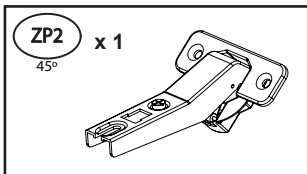

14

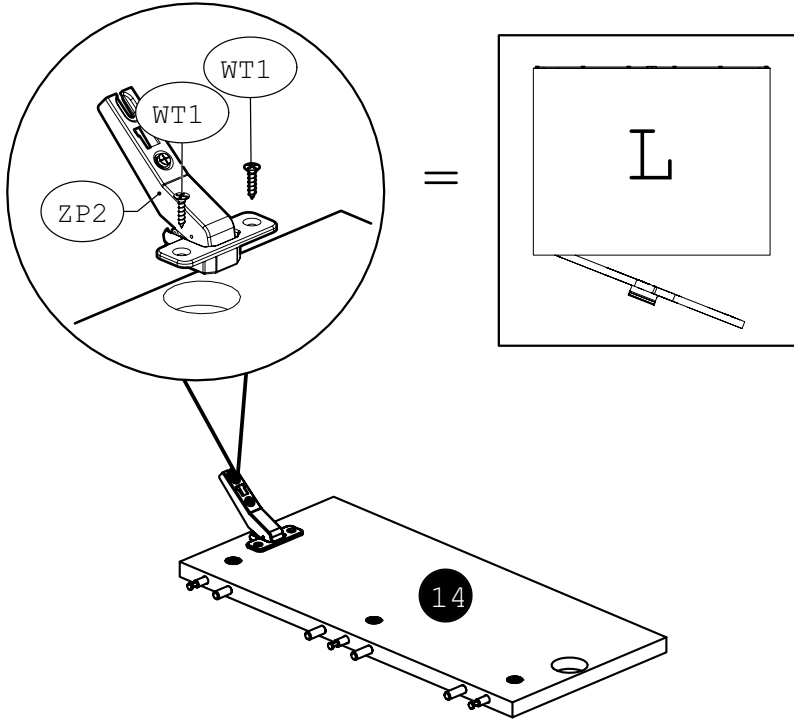

15

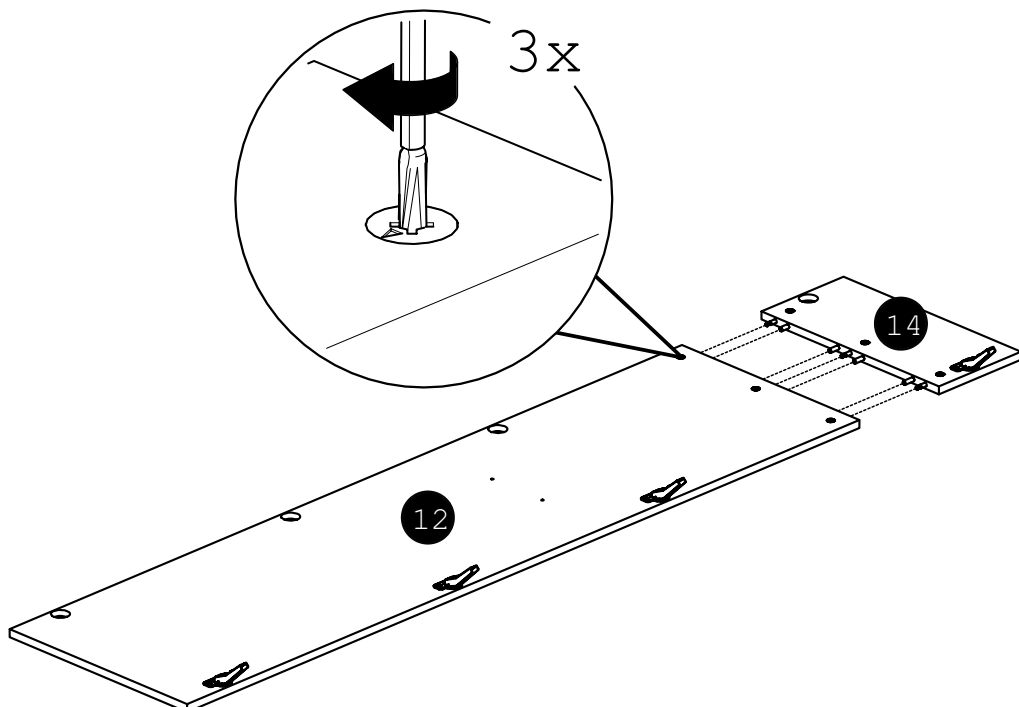
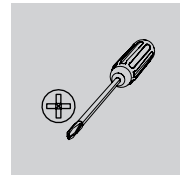

16

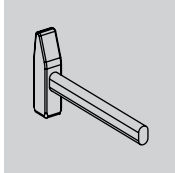
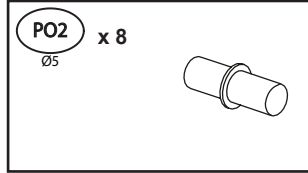
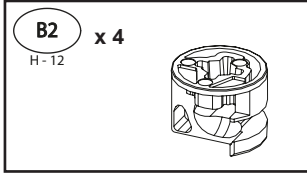

2/3

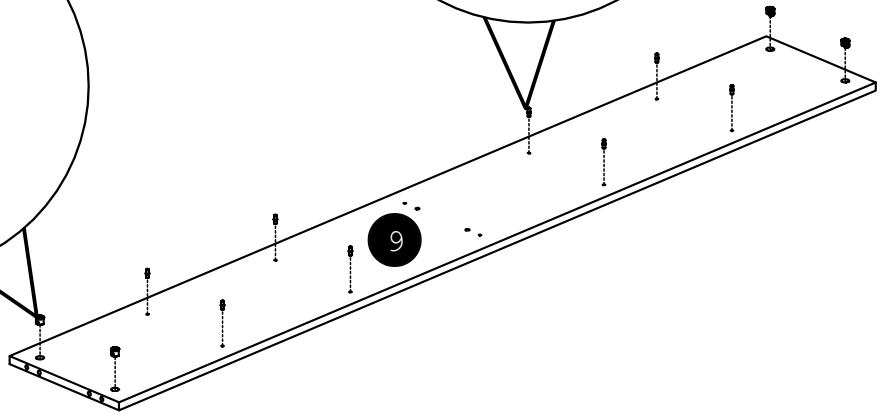
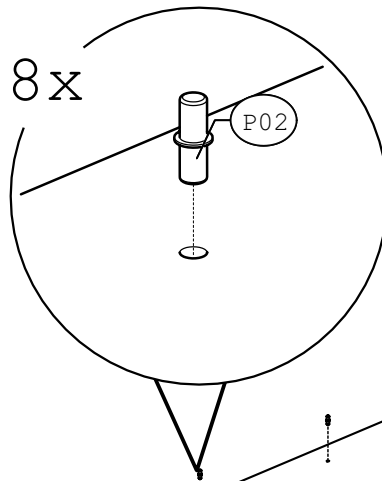
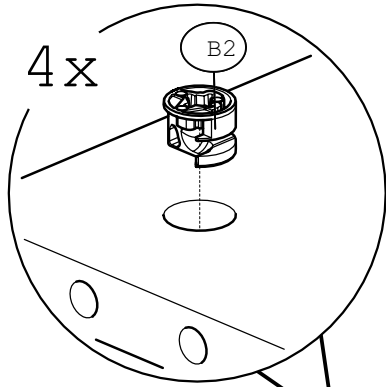
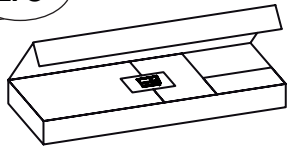

17

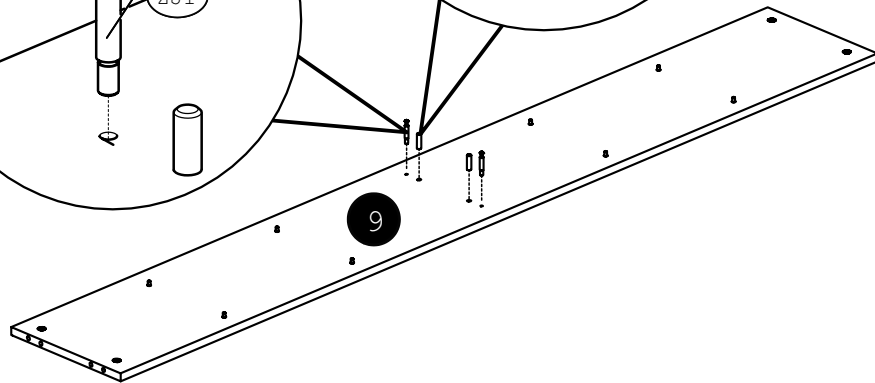
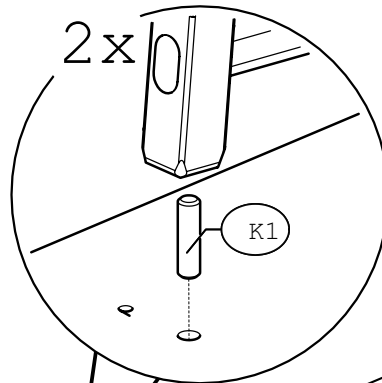
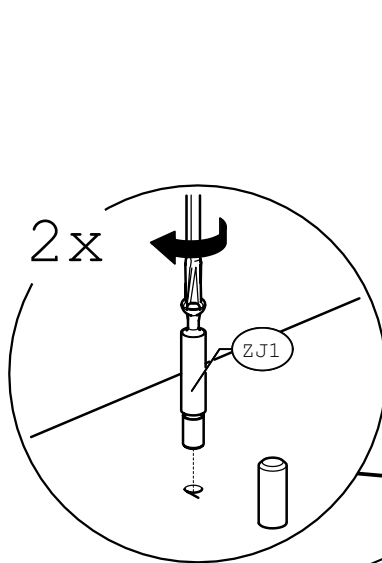
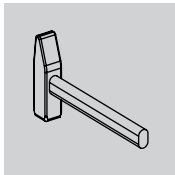
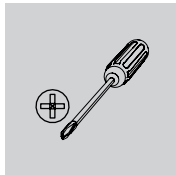
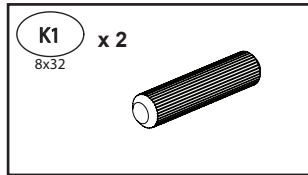
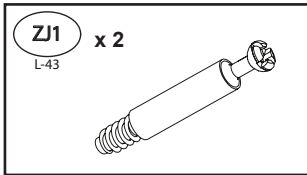

18

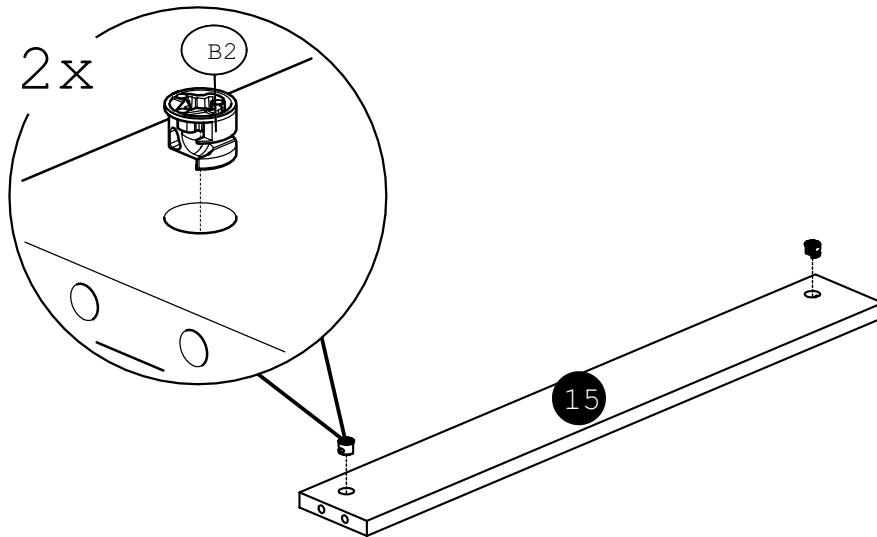
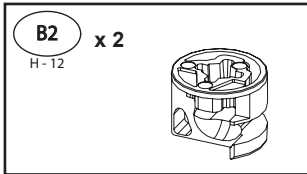

19

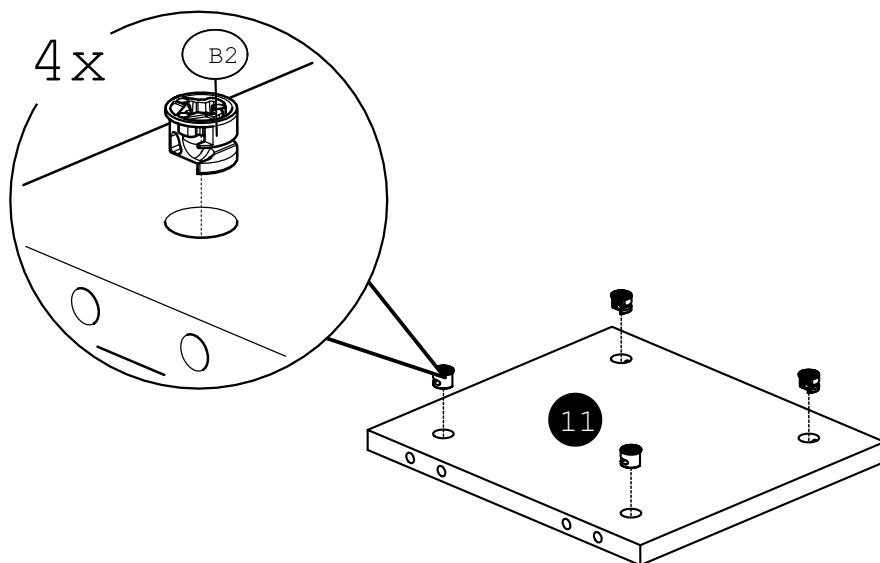
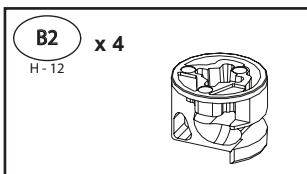

20

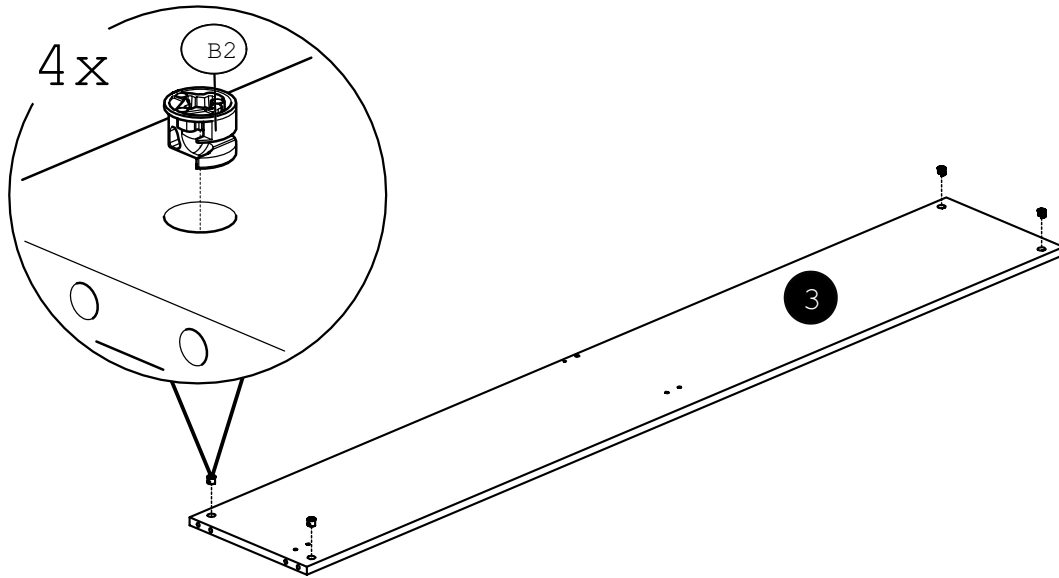
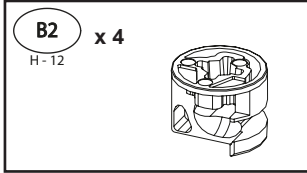

21

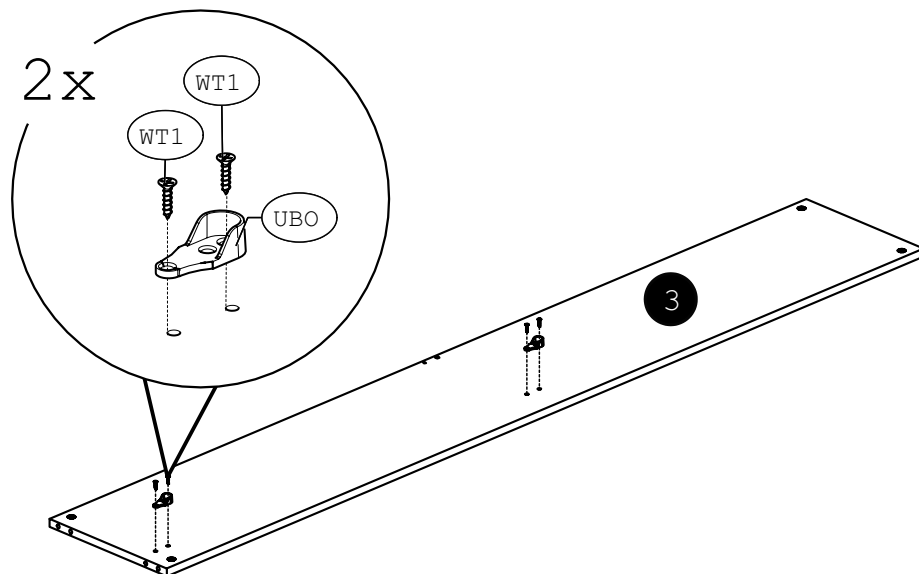
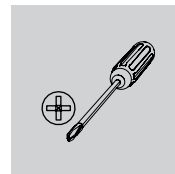
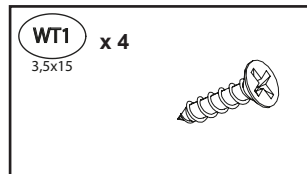
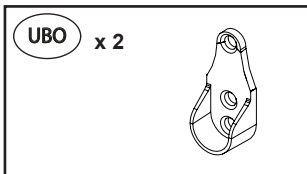

22

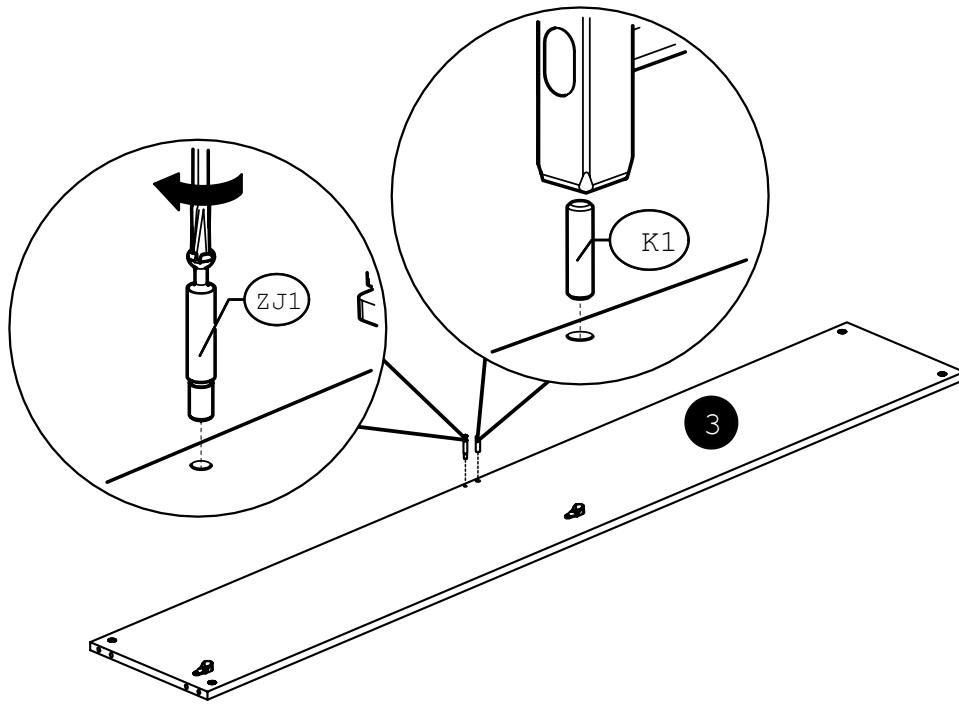
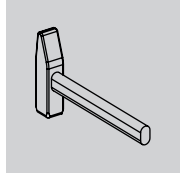
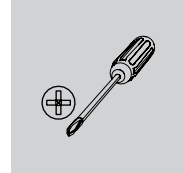
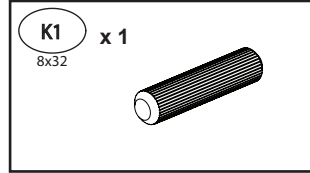
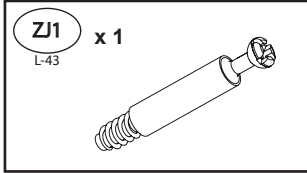

23

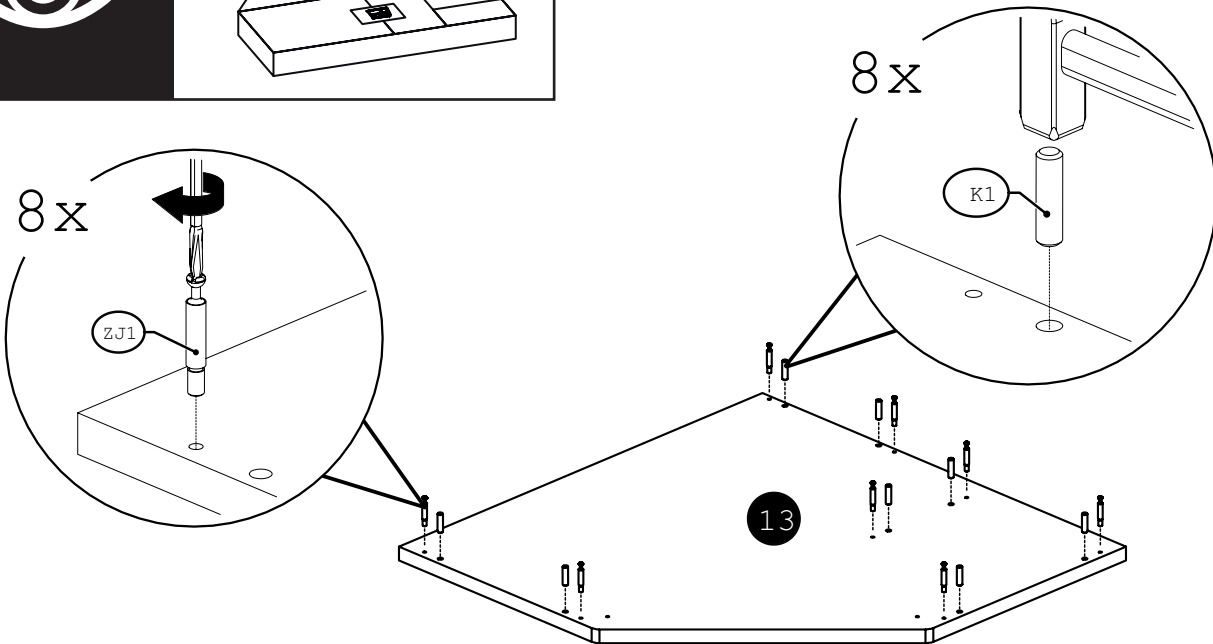
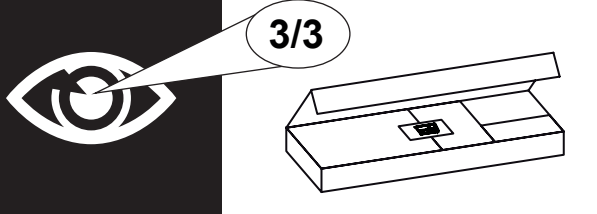
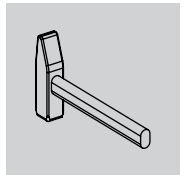
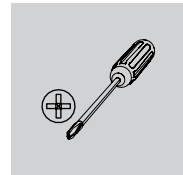
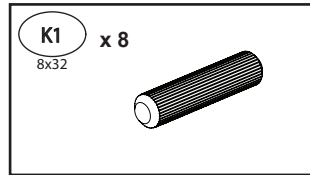
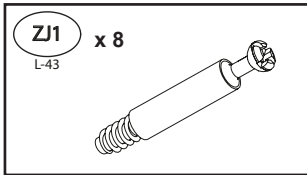

24

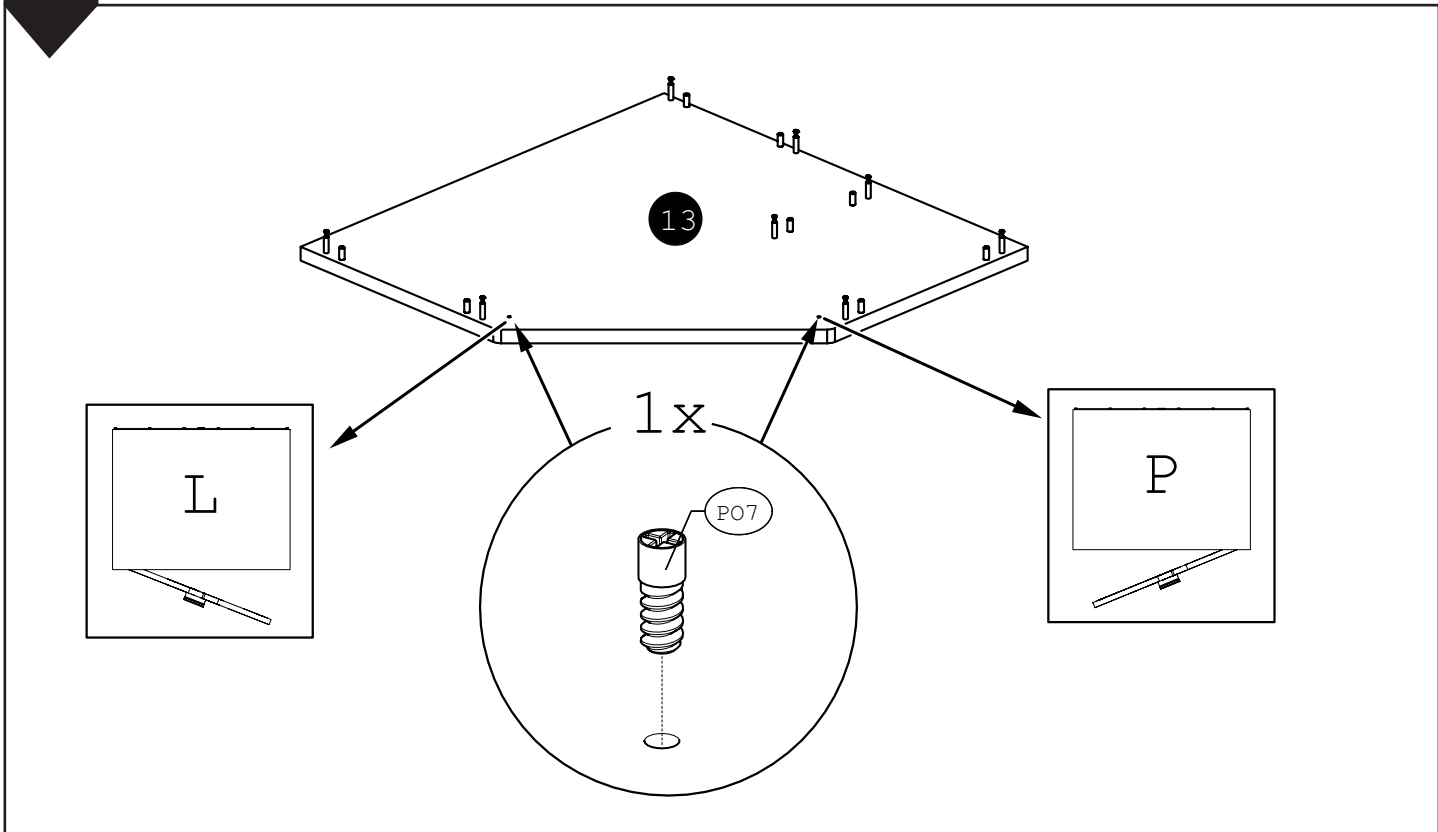
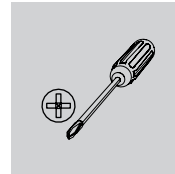
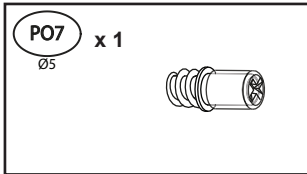

25

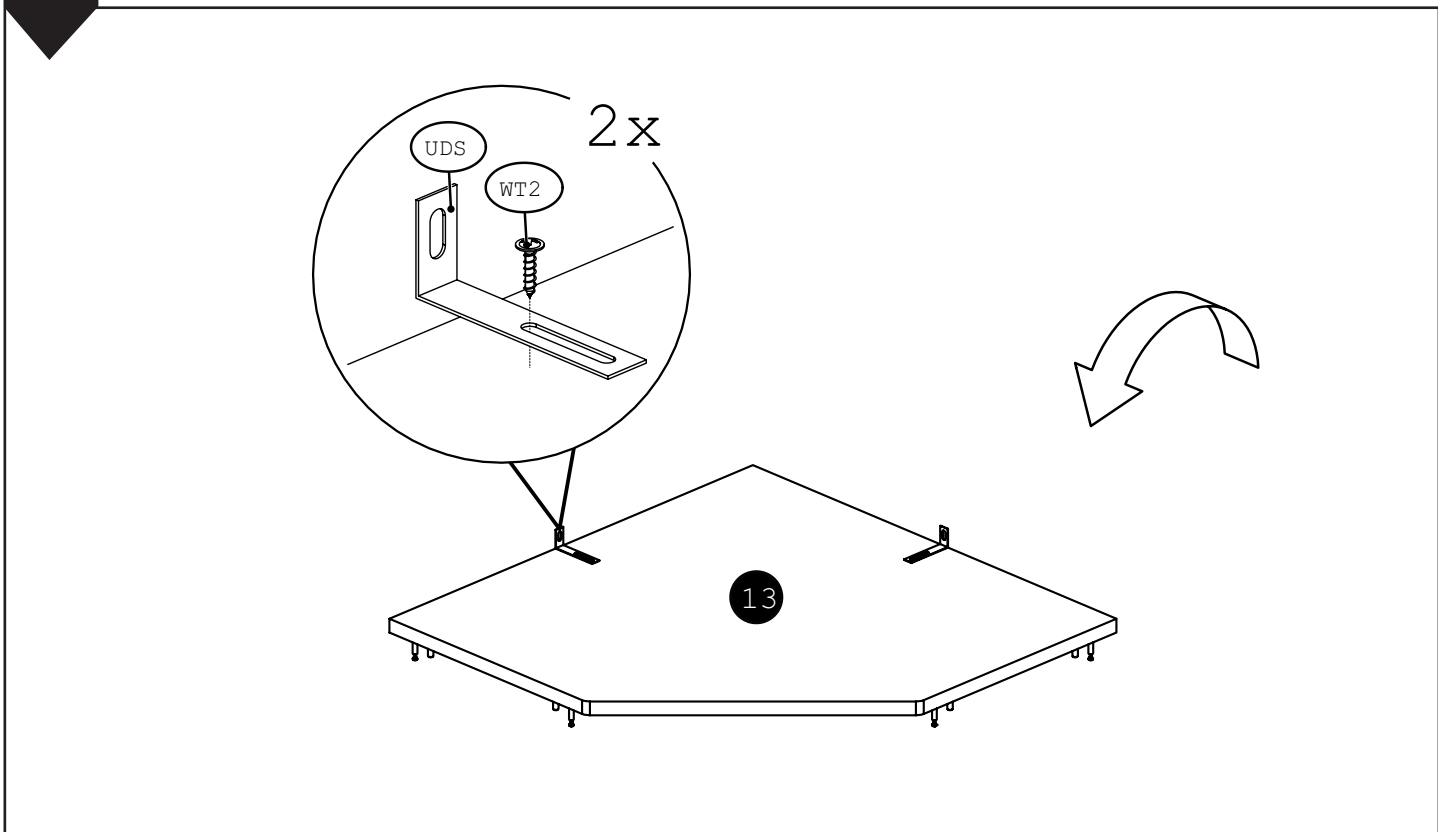
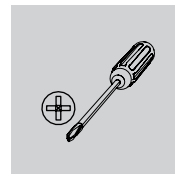
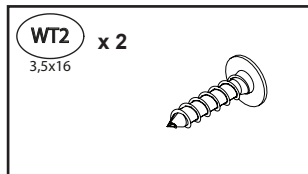
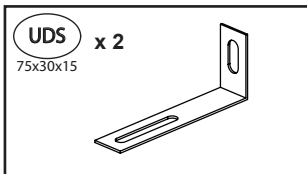

26

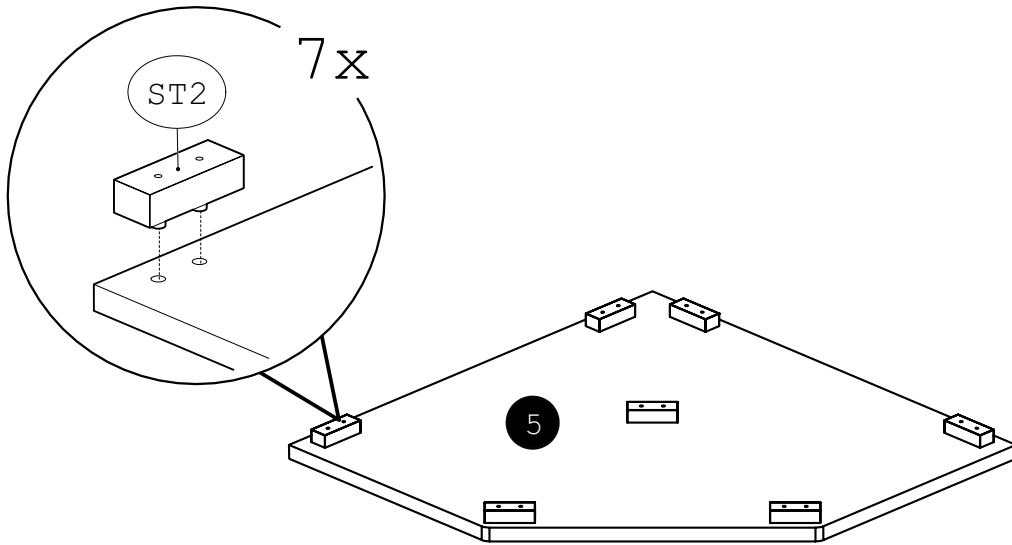
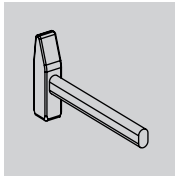
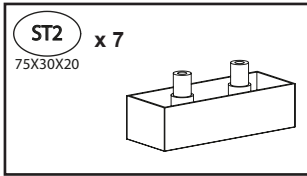

27

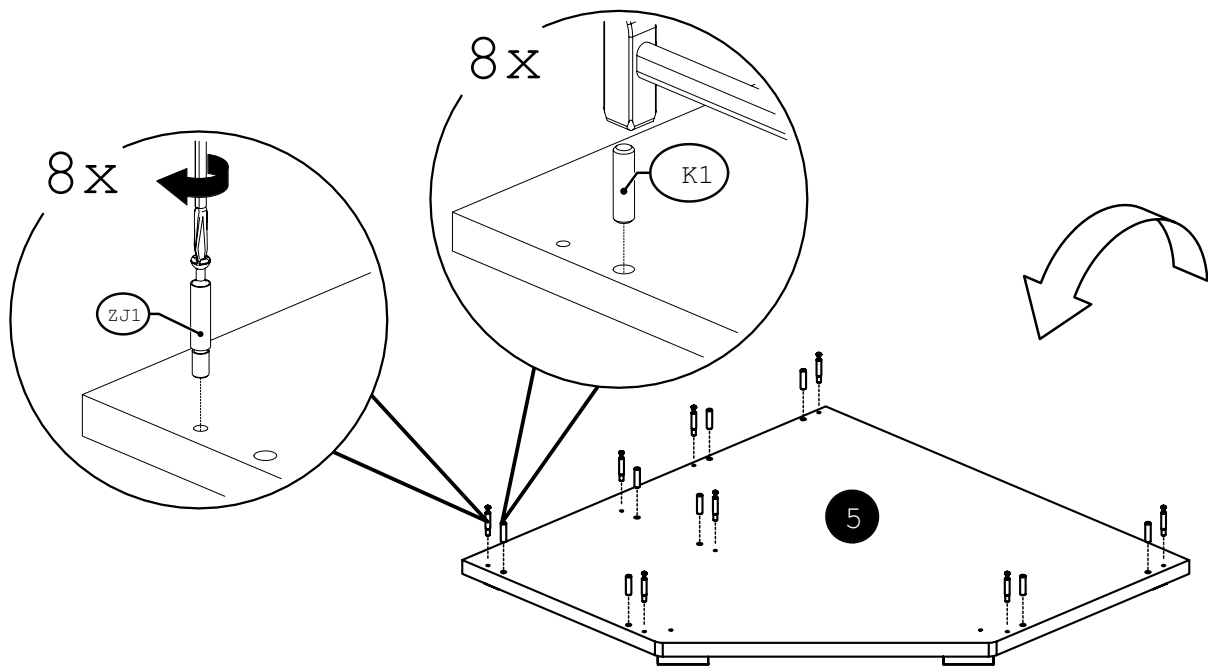
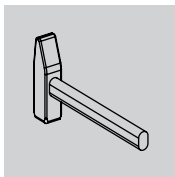
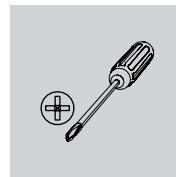
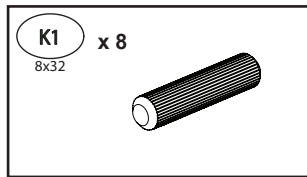
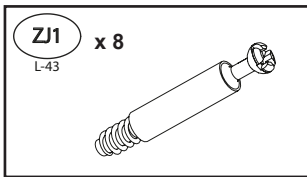

28

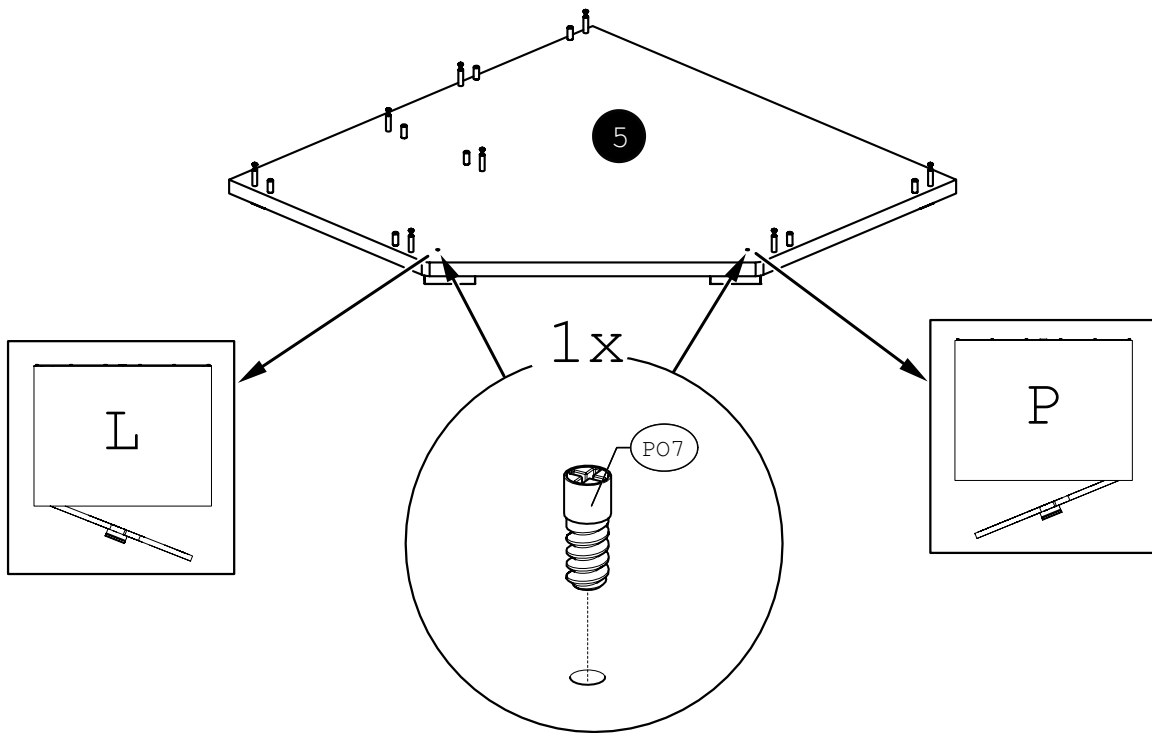
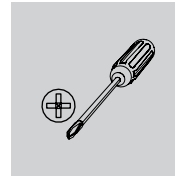
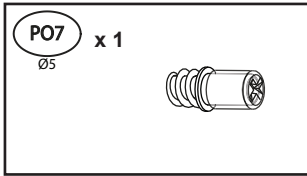

29

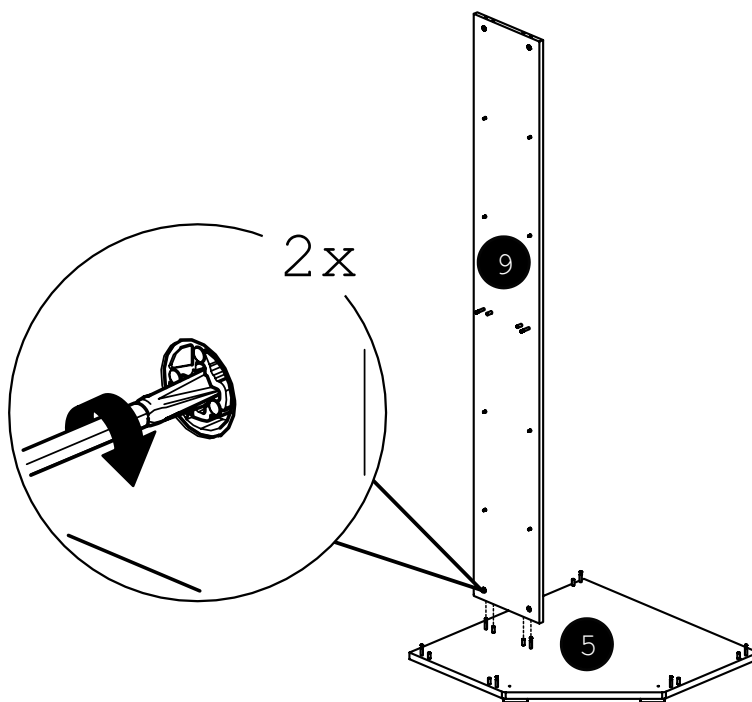
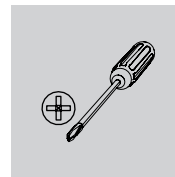

30

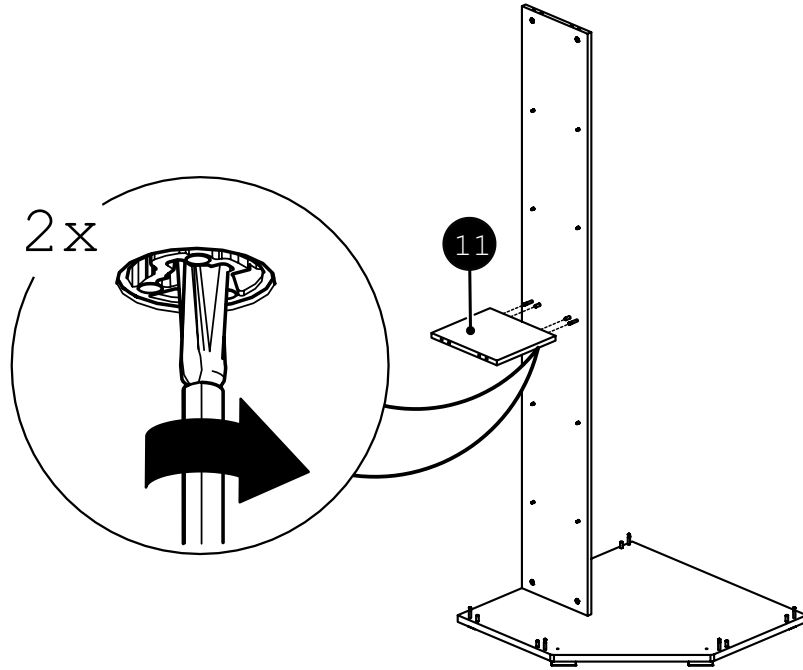
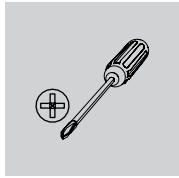

31

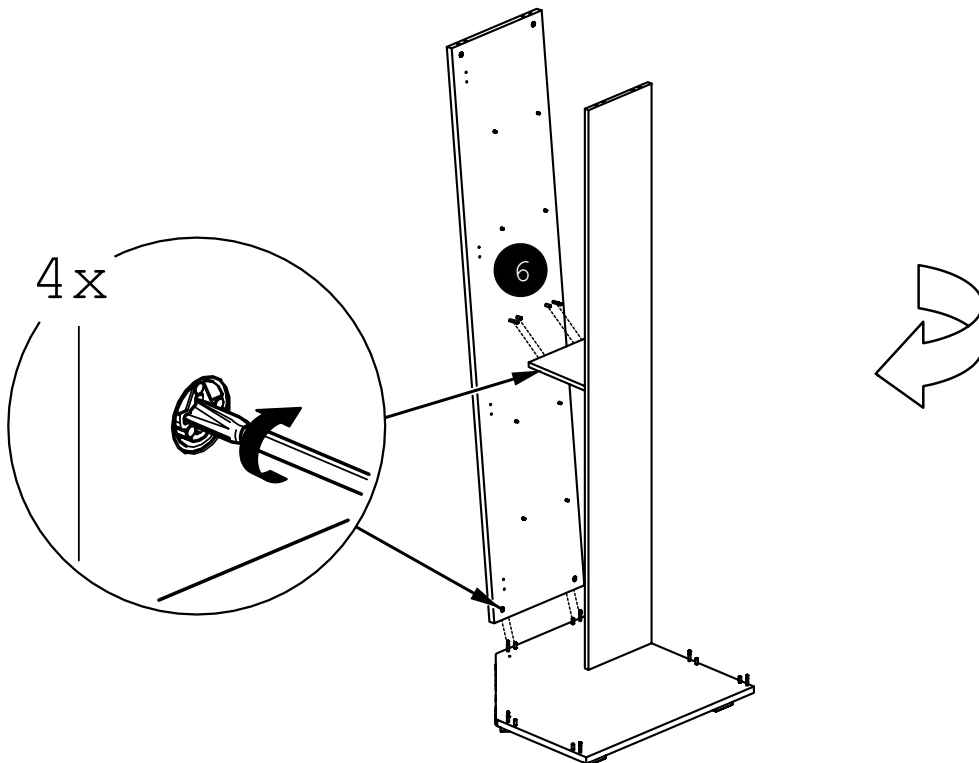
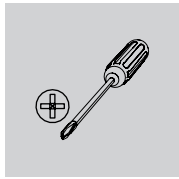

32

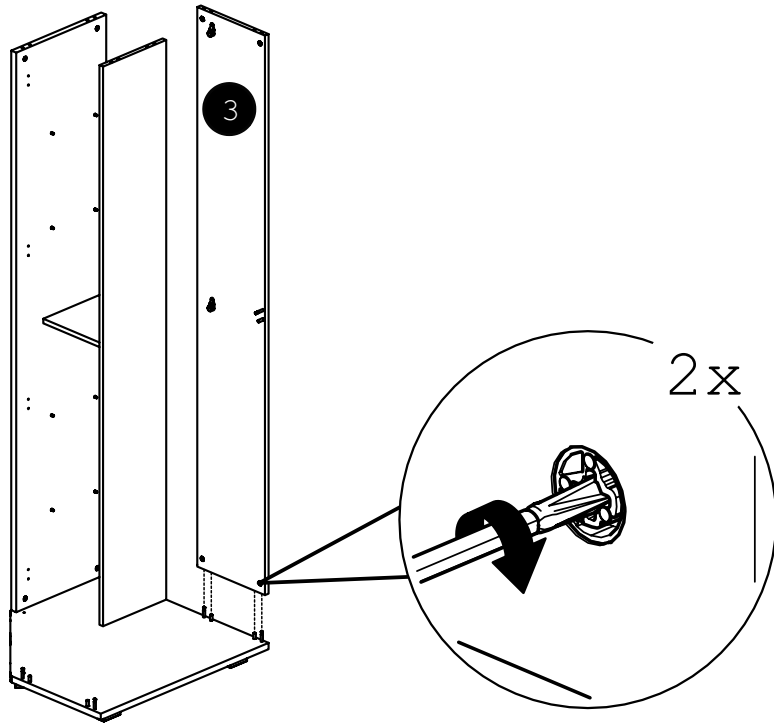
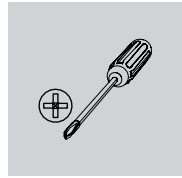

33

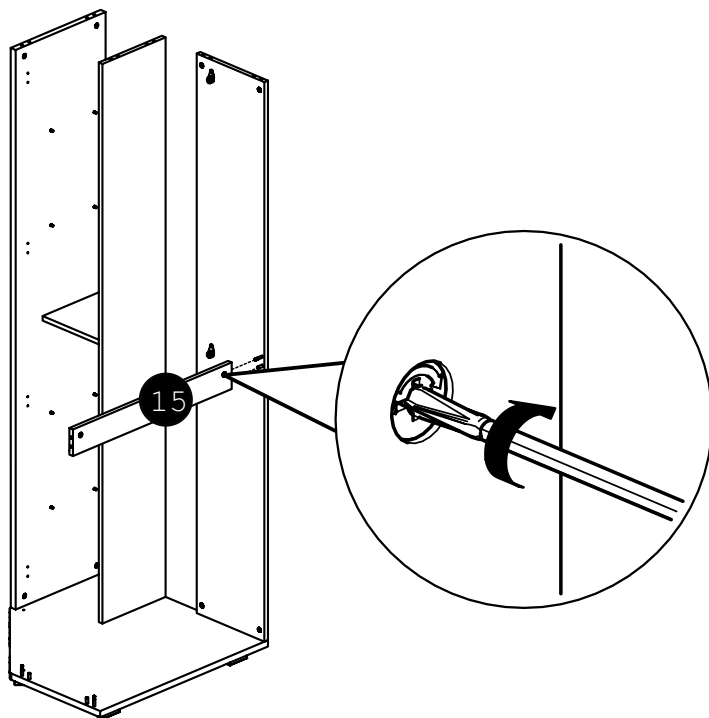
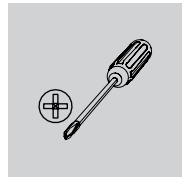

34

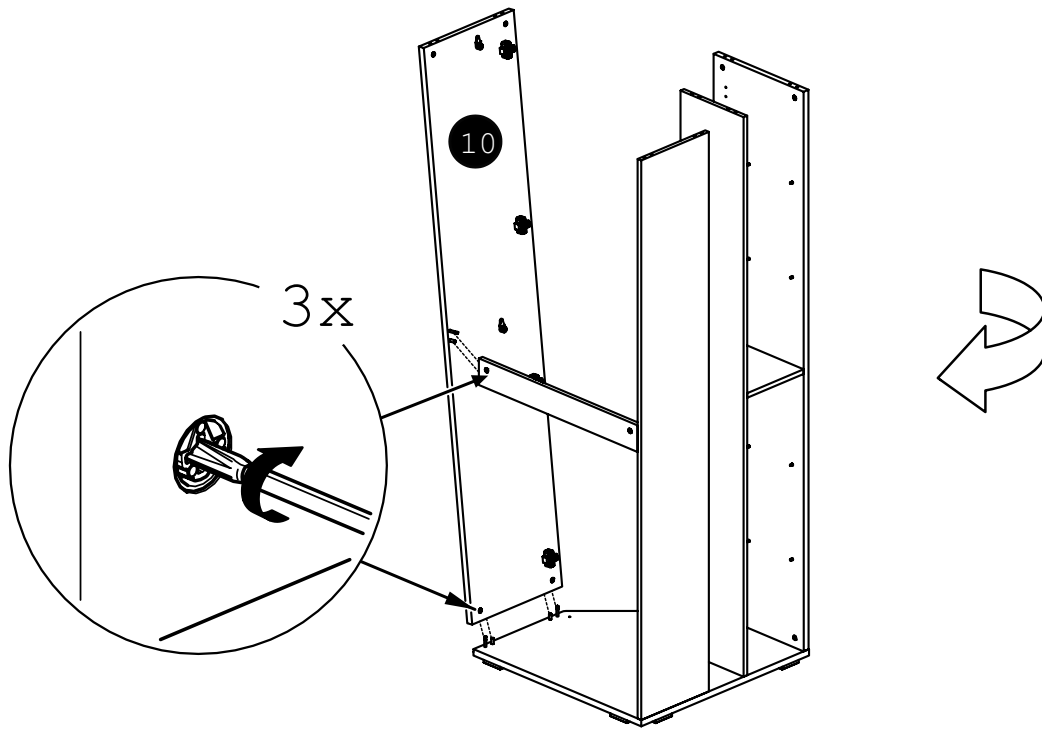
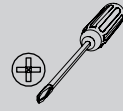

35

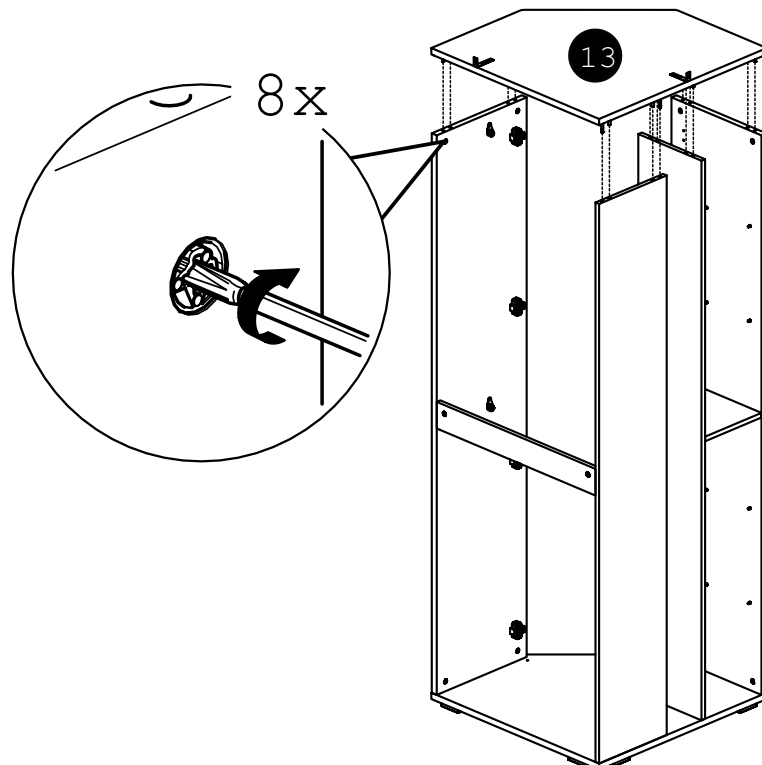
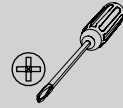

36

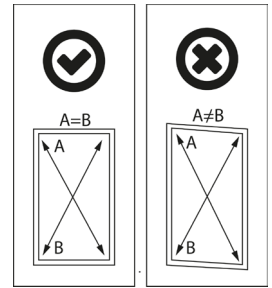
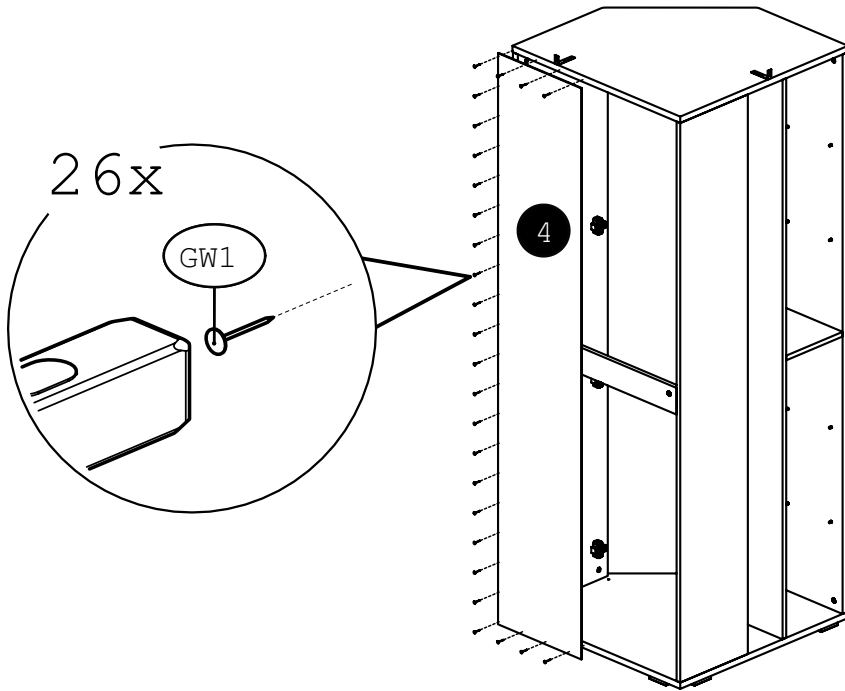
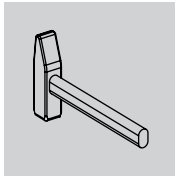
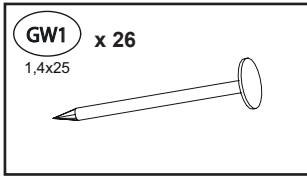

37

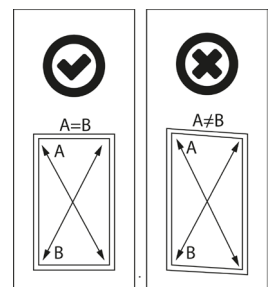
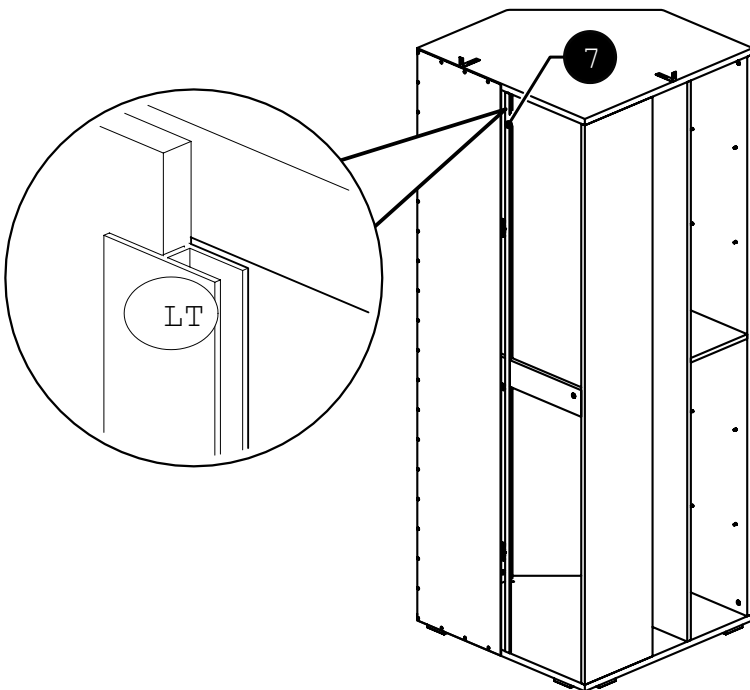
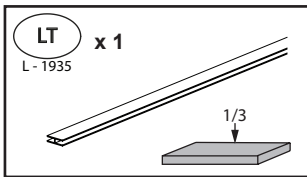

38

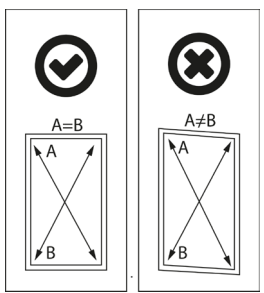
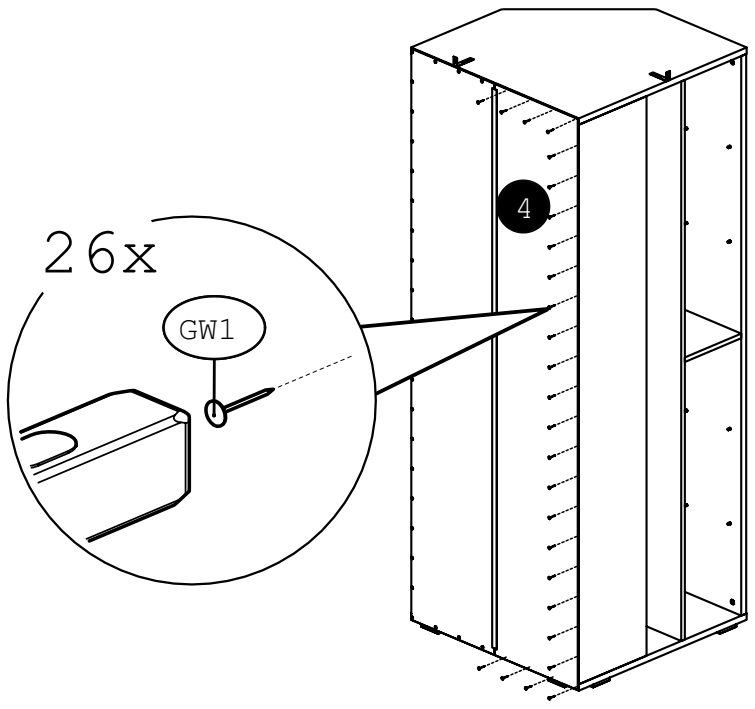
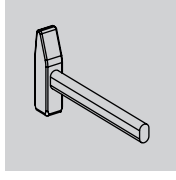
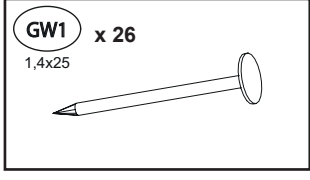

39

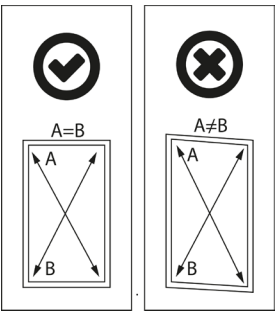
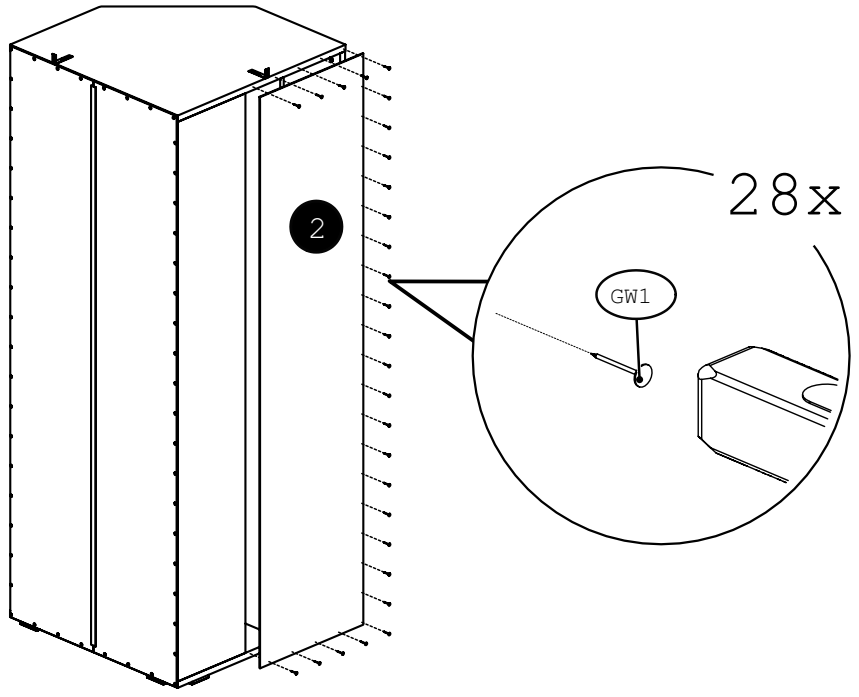
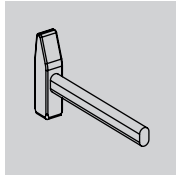
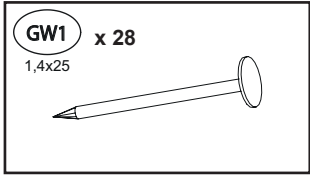

40

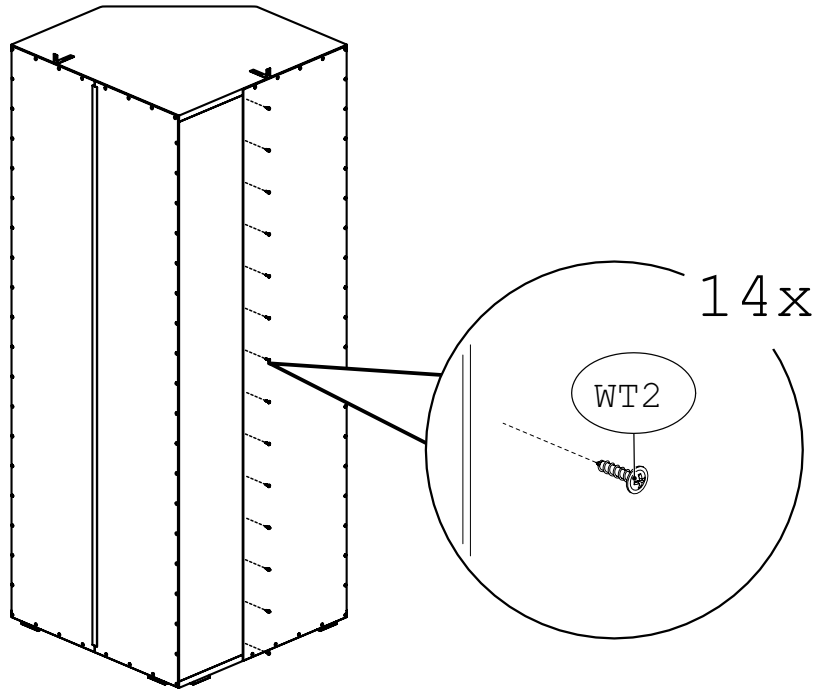
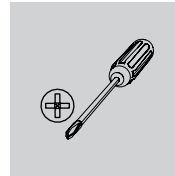
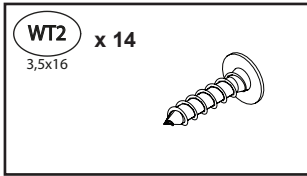

41

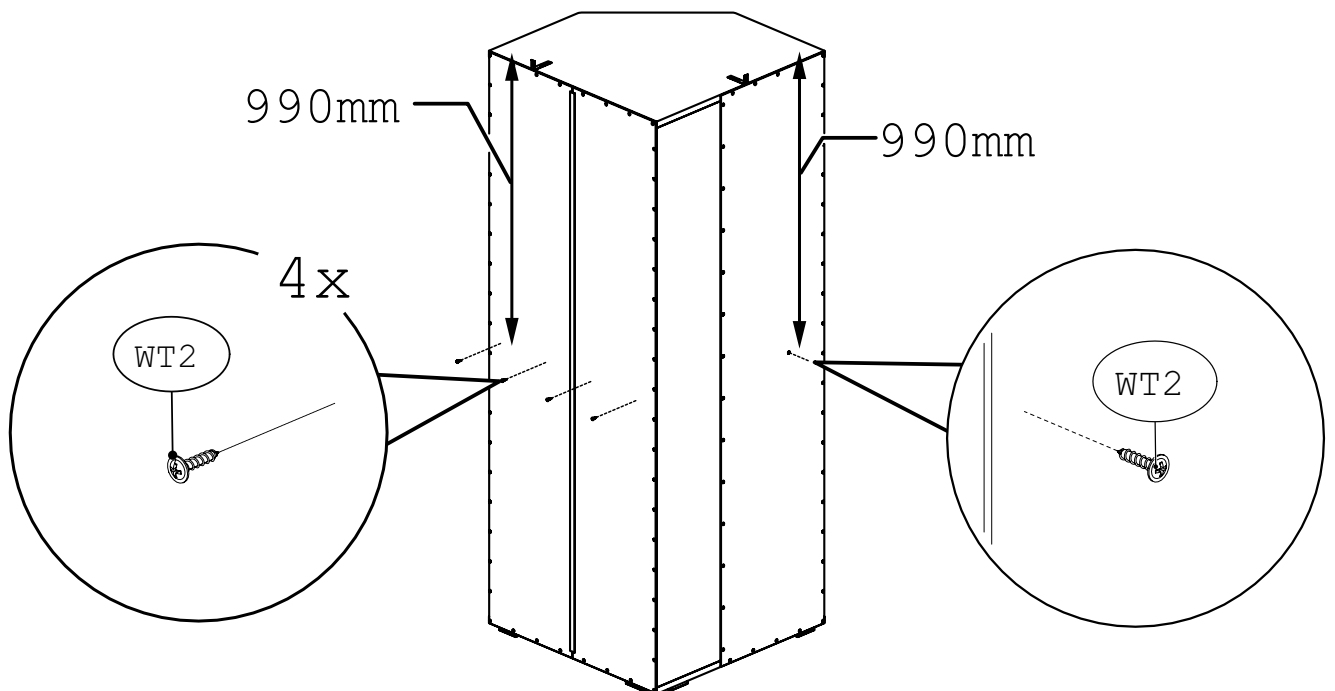
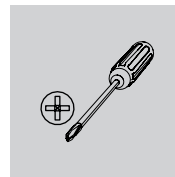
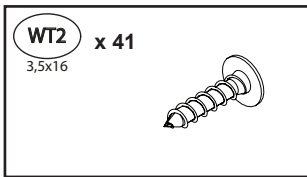

42

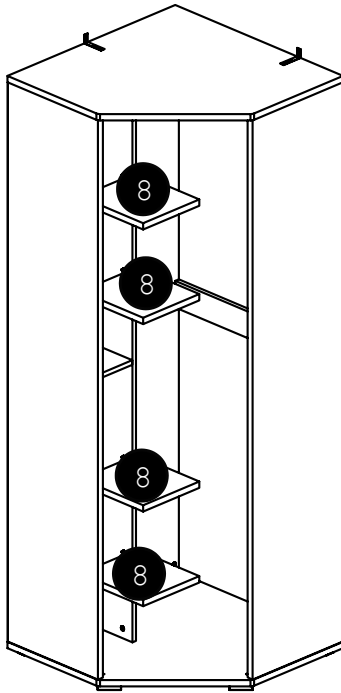

43

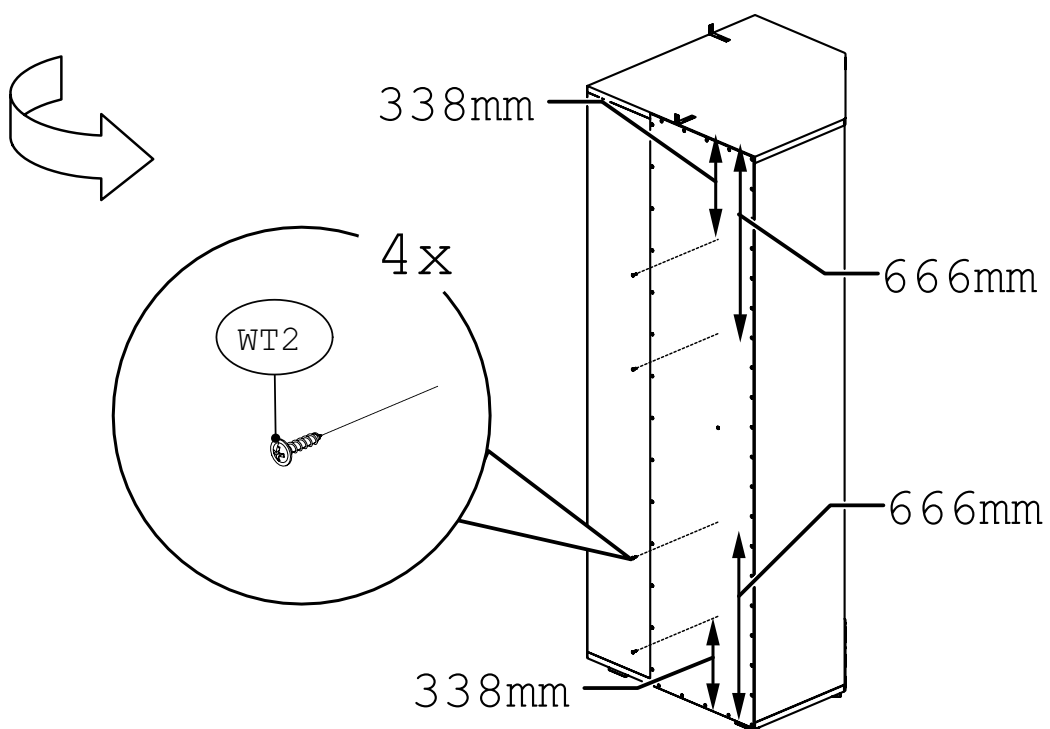
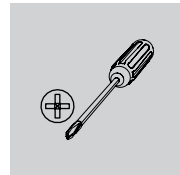
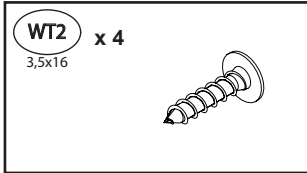

44

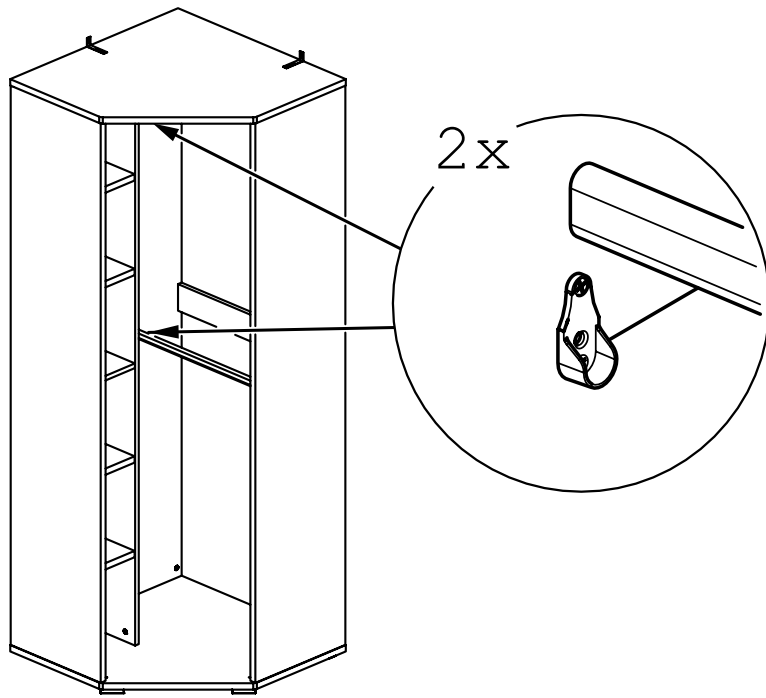
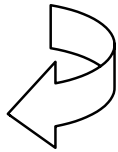
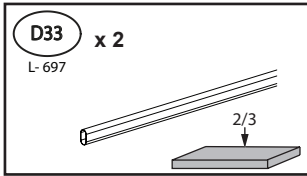

45

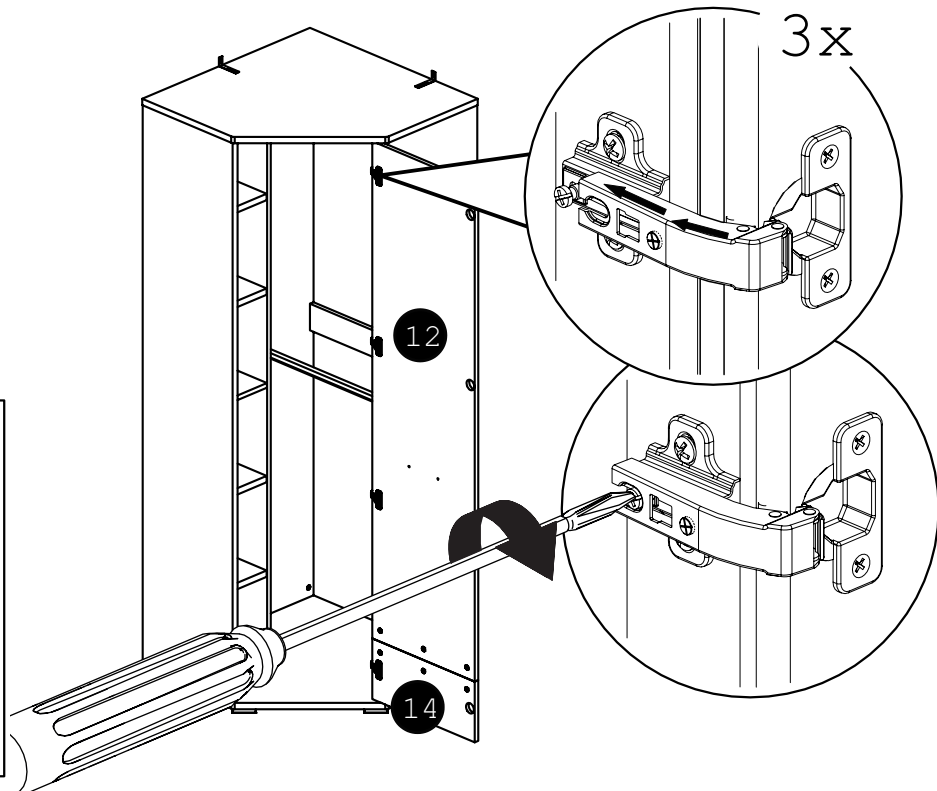
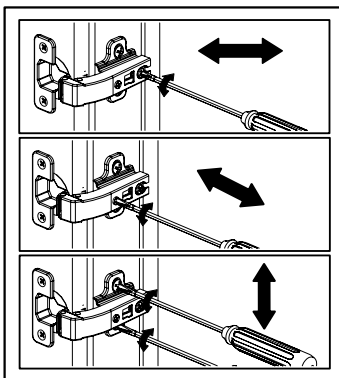
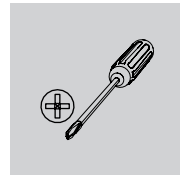

46

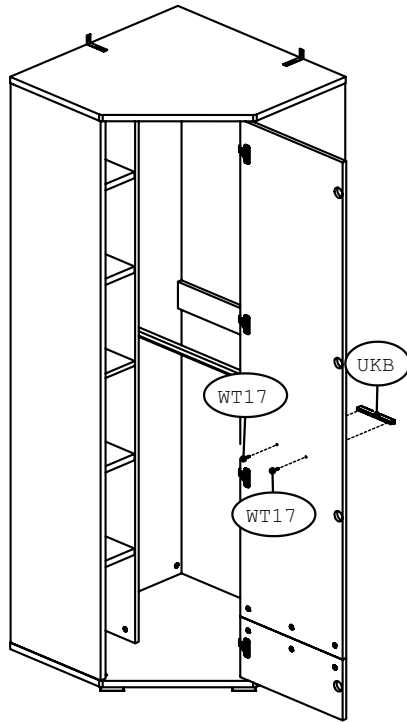
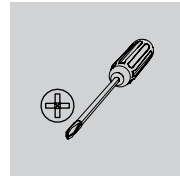
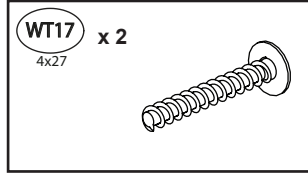
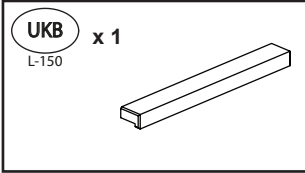

47

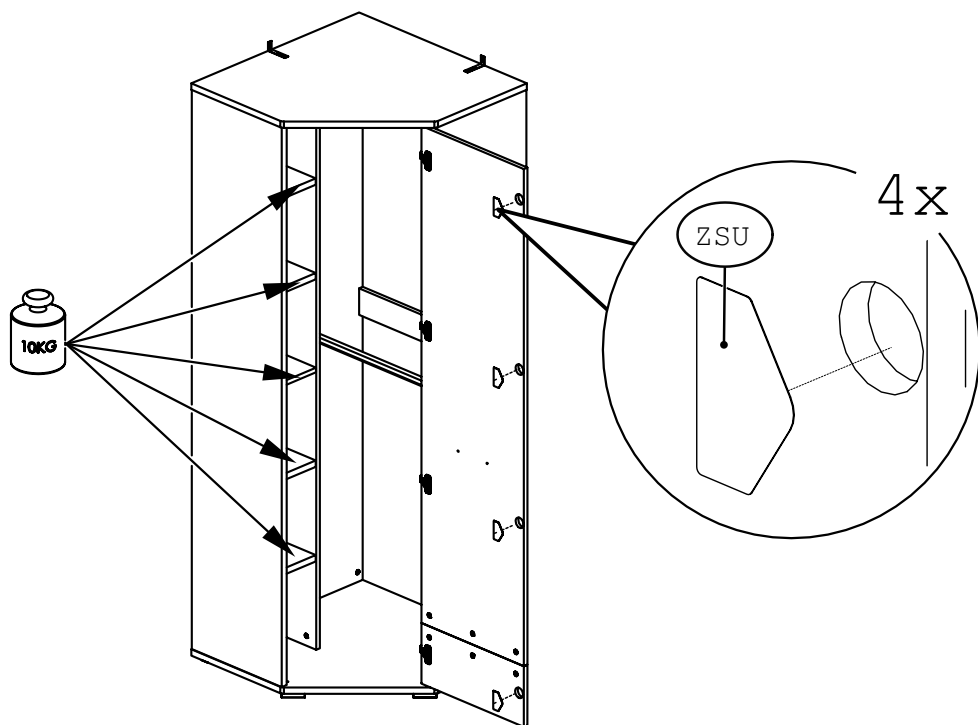
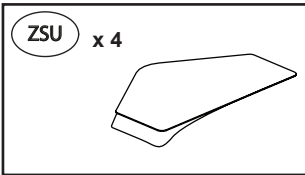



PL –
Przed zawieszeniem mebla, lub przymocowaniem go do ściany (w celu zabezpieczenia przed przewróceniem), sprawdź wcześniej rodzaj i wytrzymałość ściany. Dobierz odpowiednie kołki i wkręty do rodzaju ściany. W przypadku wątpliwości skontaktuj się ze specjalistą. Montaż musi zostać wykonany przez osobę kompetentną.

BG –
Преди да закачите мебела, или преди да го прикрепите към стената (за да се предотврати падането), проверете предварително вида и силата на стената. Използвайте дюбели и винтове подходящи за вида на стената. В случай на съмнение, консултирайте се със специалист. Монтажът трябва да бъде извършен от компетентно лице.

CZ –
Před zavěšením nábytku nebo jeho připevněním ke zdi (za účelem zajištění před převrácením) dřívě zkontrolujte druh a odolnost stěny. Vyberte k druhu stěny vhodné hmoždinky a šrouby. V případě pochybností kontaktujte specialistu. Montáž musí být provedena kompetentní osobou.

DE –
Bevor Sie ein Möbelstück an einer Wand aufhängen oder befestigen (um es gegen Umkippen zu sichern), prüfen Sie Art und Tragfähigkeit der Wand. Wählen Sie die für die Wand geeigneten Dübel und Schrauben. Im Zweifelsfall kontaktieren Sie bitte einen Fachmann. Die Montage muss durch eine sachkundige Person ausgeführt werden.

EN –
Before suspending or fixing furniture to the wall (in order to prevent falling over), check the type and strength of the wall. Select wall plugs and screws appropriate for the given type of the wall. In the case of doubts, contact a specialist. The installation must be performed by a competent person.

ES –
Antes de colgar o fijar el mueble en el muro (a fin de proteger contra el vuelco del mueble), compruebe de antemano la naturaleza y la resistencia de la pared. Seleccione tacos y tornillos adecuados para el tipo de la pared. En caso de duda, consulte a un especialista, debiendo efectuar este montaje una persona competente.

EST –
Enne mööbli riputamist või kinnitamist seinale (ümberminekü tõkestamiseks), tuleks enne uurida seina olemust ja tugevust. Paigaldada tüüblik ja kruvid vastavalt seinale. Kahtluse korral konsulteeruda spetsialistiga. Paigaldus tuleb teostada pädeva isiku poolt.

FR –
Avant de suspendre le meuble ou de le fixer au mur (dans le but d'éviter un renversement), vérifiez au préalable le type et la résistance du mur. Utilisez les chevilles et les vis adaptées au type de mur. En cas de doute, veuillez contacter un spécialiste. Le montage doit être réalisé par une personne compétente.

HR –
Prije kačenja nameštaja ili montaže na zidu (u cilju zaštite od prevrtanja), provjerite vrstu zida i njegovu otpornost. Izaberite odgovarajuće šrafove i uvijače za određenu vrstu zida. U slučaju nejasnoća, kontaktirajte stručnjaka. Montažu treba vršiti stručno lice.

HU –
A bútor felfüggesztése illetve falhoz való rögzítése (megakadályozván ezzel eldőlésének lehetőségét) előtt ellenőrizze a fal fajtáját és szilárdságát. Megfelelő, a falhoz

illő tipliket és csavarokat használjon. Ha kétsége támadna, konzultáljon szakemberrel. A felszerelést csakis egy hozzáértő szakember végezheti el.

I –
Prima di appendere i mobili, oppure attaccarli al muro (per proteggerli da ribaltamenti), verifica prima la tipologia e resistenza del muro. Scegli i tasselli e viti più adatti per il tipo di muro. In caso di dubbi contattare uno specialista. Il montaggio deve essere fatto da una persona competente.

LV –
Pirms pakarat, piestiprināt mēbēli pie sienas (lai to aizsargātu pret apgāšanos), pārbaudiet sienas veidu un neatspēju. Izvēlieties sienas veidam atbilstošus dibēļus un skrūves. Šaubu gadījumā sazinieties ar speciālistu. Montāža jāveic kvalificētai personai.

LT –
Norint pakabinti baldus (arba pritvirtinti prie sienos), reikia patikrinti sienos kokybę ir stiprumą. Reikia pasirinkti varžtus tinkamus sienos tipui. Kilus klausimams raginame kreiptis į specialistus. Montavimą turi atlikti kompetentingas asmuo.

NL –
Voordat u het meubel ophangt of bevestigt tegen de muur (om het te beschermen tegen omvallen) dient u het type en de duurzaamheid van deze muur na te kijken. Maak gebruik van pluggen en schroeven die geschikt zijn voor het type muur. Neem in geval van twijfels contact op met een specialist. De assemblage dient te worden uitgevoerd door iemand met kennis van zaken.

P –
Antes de pendurar ou fixar o móvel na parede (a fim de proteger contra a sua queda), verifique com antecedência a sua natureza e resistência. Seleccione buchas e parafusos adequados para o tipo da parede. Em caso de dúvida, consulte um especialista. A montagem deve ser efetuado por uma pessoa competente.

RO –
Înainte de suspendarea unei piese de mobilier sau atașarea acestuia la perete (pentru a preveni bascularea), verificați în prealabil tipul și gradul de rezistență a peretelui. Montați diblurile și șuruburile adecvate pentru tipul de perete. În caz de îndoieli, consultați un specialist. Instalarea trebuie să fie efectuată de către o persoană competentă.

RU –
Перед подвешиванием мебели или ее креплением к стене (для защиты от падений) проверьте предварительно тип и прочность стены. Подберите соответствующие типу стены дюбели и шурупы. При возникновении сомнений свяжитесь со специалистом. Монтаж должен проводиться компетентным лицом.

S –
Innan möbelen hängs upp eller förankras i väggen (så att den inte välter), kontrollera först hur väggen är uppbyggd och hur mycket den kan belastas. Välj sedan lämplig väggplugg och skruv. Om du är osäker ta kontakt med en specialist. Montage måste utföras av kompetent person.

SK –
Pred zavesením nábytku alebo jeho pripevnením na stenu (za účelom zaistenia pred prevrátením) predtým skontrolujte druh a odolnosť steny. Vyberte k druhu steny vhodné hmoždinky a skrutky. V prípade pochybností kontaktujte špecialistu. Montáž musí byť vykonaná kompetentnou osobou.

SLO –
Pred montažo pohištva na steno ali pritrditve le-tega k steni (v cilju preprečitve, da se ne prevrne) prej preverite vrsto in močnost stene. Izberite vložke in vijake, ki odgovarjajo vrsti stene. V primeru dvomov se posvetujte s specialistom. Montažo sme opraviti izključno ustrezno kvalificirana oseba.

SRB –
Pre vešanja nameštaja, ili pričvršćivanja ga do zida (radi

osiguranja od prevrtanja), treba unapred proveriti vrstu i izdržljivost zida. Treba birati odgovarajuće eksere i vijke prema određenoj vrsti zida. U slučaju sumnje kontaktirati se sa stručnjakom. Montažu mora izvršiti kompetentno lice.

TR –
Mobilyayı duvara asmadan veya montaj etmeden önce (devrilmesini önlemek için) duvarın türünü ve dayanıklılığını kontrol edin. Duvara uygun dübelleri ve vidaları seçin. Emin olamamanız durumunda bir uzman ile irtibata geçin. Kurulum yetkili bir kişi tarafından yapılmalıdır.

UKR –
Перед підвішуванням меблів або їх кріпленням до стіни (з метою захисту від падіння) перевірте попередньо тип та міцність стіни. Підберіть відповідні типу стіни дюбелі та шурупи. При наявності сумнівів зв'яжіться зі спеціалістом. Монтаж повинен проводитися компетентною особою.

PL - Mocowanie mebla do ściany / BG - Закрепване на мебелите към стената / CZ - Upevnění nábytku ke zdi / DE - Befestigung der Möbel an der Wand / EN - Fixing the furniture to the wall / ES - Fijando los muebles a la pared / EST - Mööbli kinnitamine seinalle / FR - Fixation des meubles au mur / HR - Ugradnja namještaja na zid / HU - A bútorok falhoz rögzítése / I - Fissare i mobili al muro / LT - Baldų tvirtinimas prie sienos / LV - Mēbeļu piestiprināšana pie sienas / NL - Het meubilair aan de muur bevestigen / P - Fixando a mobília na parede / RO - Fixarea mobilierului pe perete / RU - Крепление мебели к стене / S - Fäster möblerna på väggen / SK - Pripevnenie nábytku k stene / SLO - Pritrditev pohištva na steno / SRB - Спајање намештаја на зид / TR - Mobilyayı duvara sabitleme / UKR - Кріплення меблів до стіни /

