

MODELL: ATO2

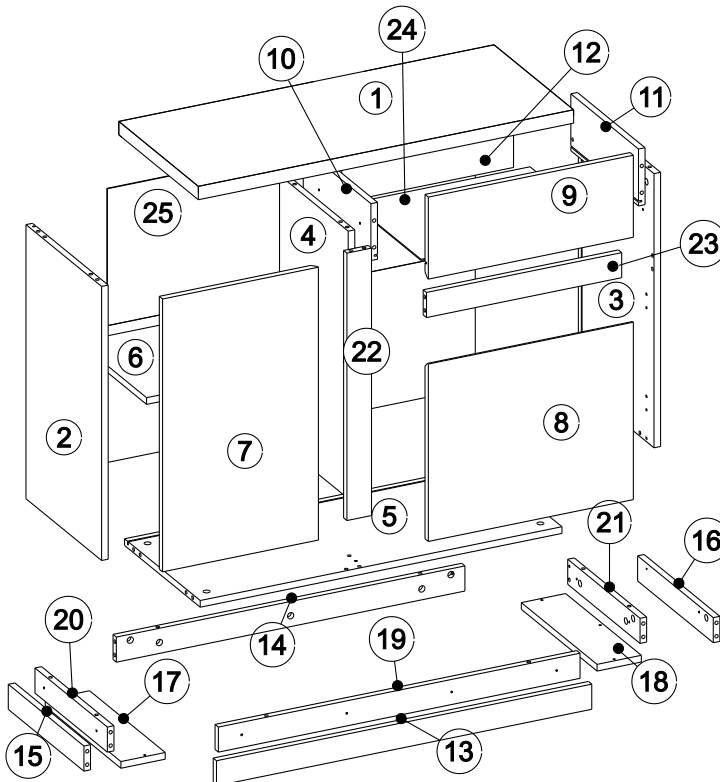

25	654x897	1/3
24	336x434	1/3
23	476x60	1/3
22	639x60	1/3
21	353x60	1/3
20	353x60	1/3
19	882x60	1/3
18	369x108	1/3
17	369x108	1/3
16	369x60	1/3
15	369x60	1/3
14	850x60	1/3
13	915x60	1/3
12	419x124	1/3
11	330x136	1/3
10	330x136	1/3
9	500x196	3/3
8	424x500	3/3
7	652x380	3/3
6	389x334	2/3
5	882x369	1/3
4	639x335	2/3
3	655x369	2/3
2	655x369	2/3
1	916x388	1/3

16x #20/981 ZN1	12x 3.5x16 W3	10x ST1	1 kpl. #300 PK3	4x B1	10x *	4x ZC90	16x 4x30 W4	4x N1
4x 6.4x50 K5	26x 8x30 K1	2x Z10	1x K20	28x #15/15 M1	28x DU232T T1	12x 3.5x20 W8	9x 2x20 G1	8x 5x11 E1

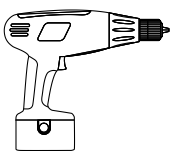
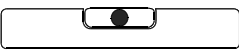
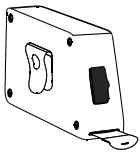
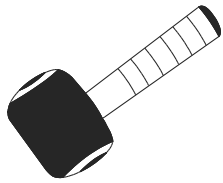
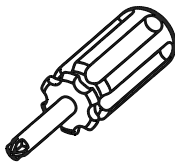
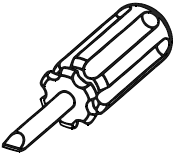
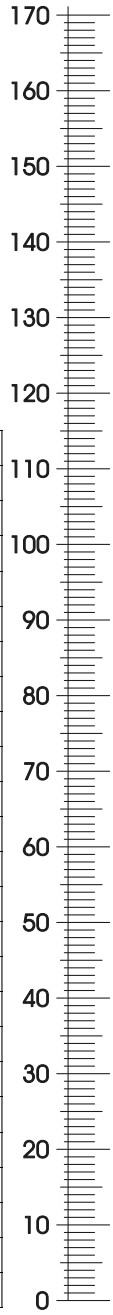
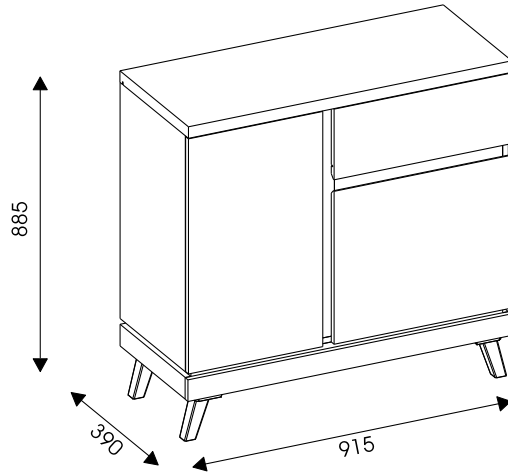
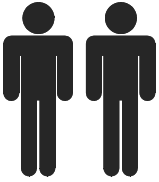
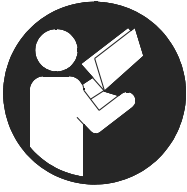
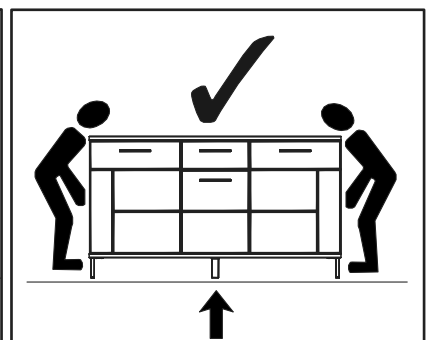
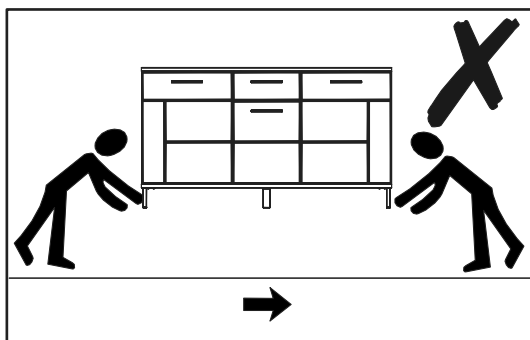
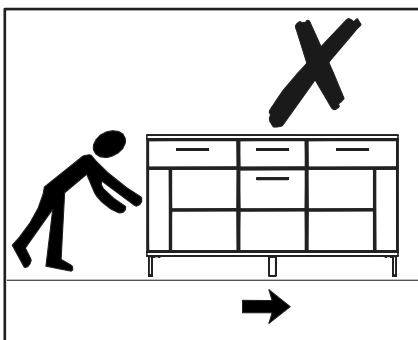
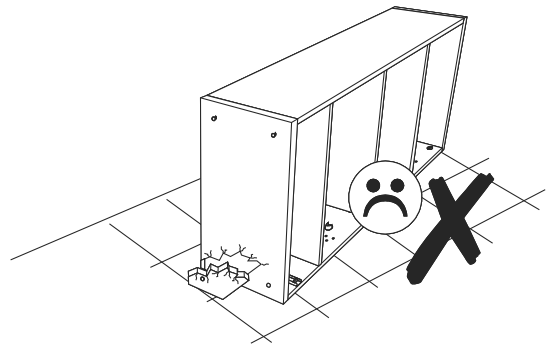
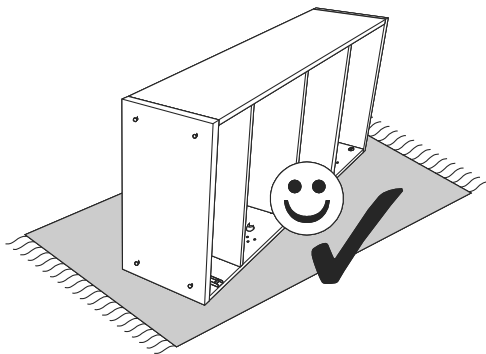
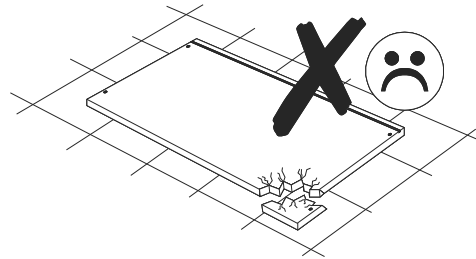
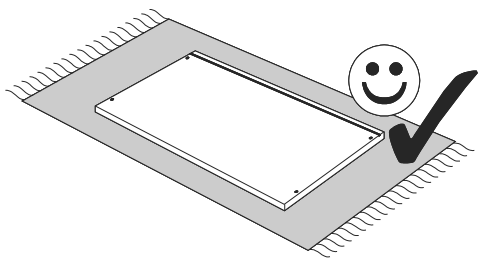
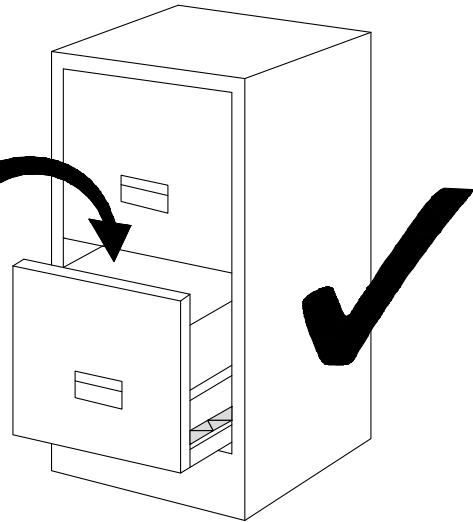
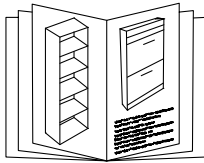
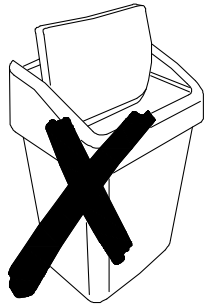

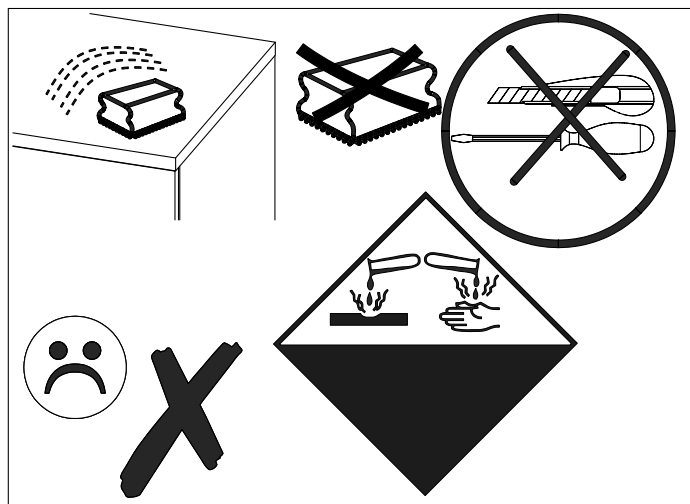
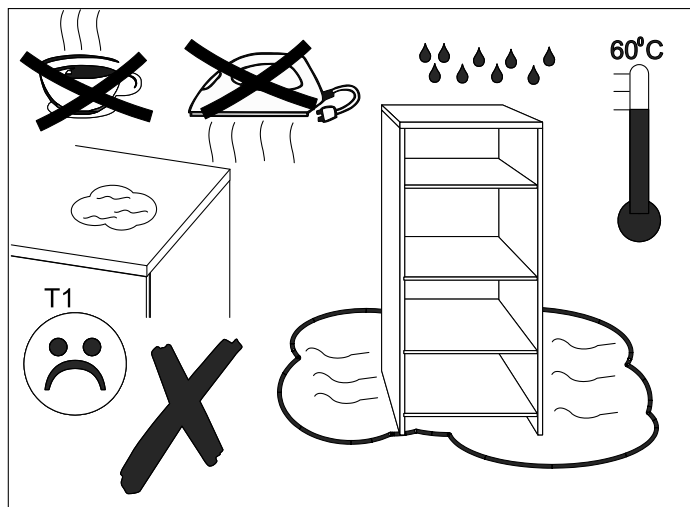
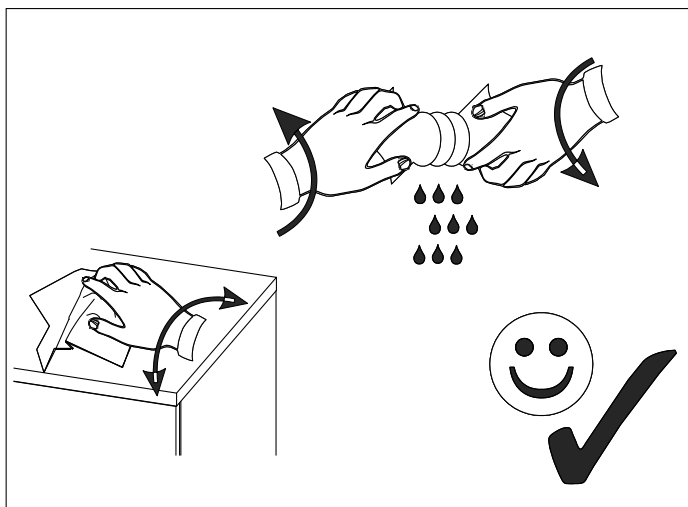
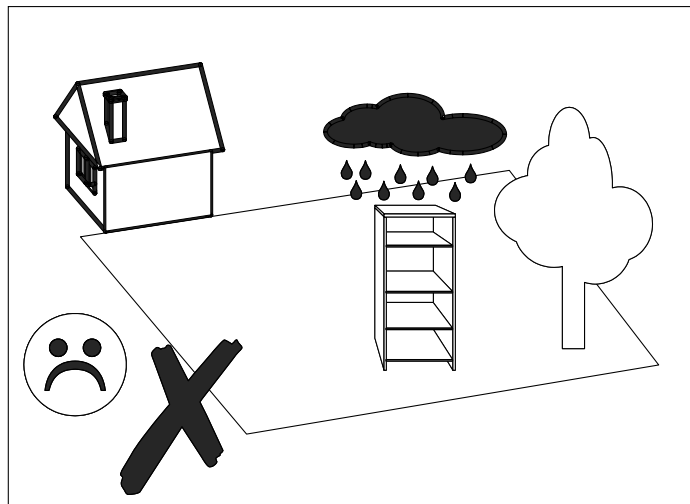
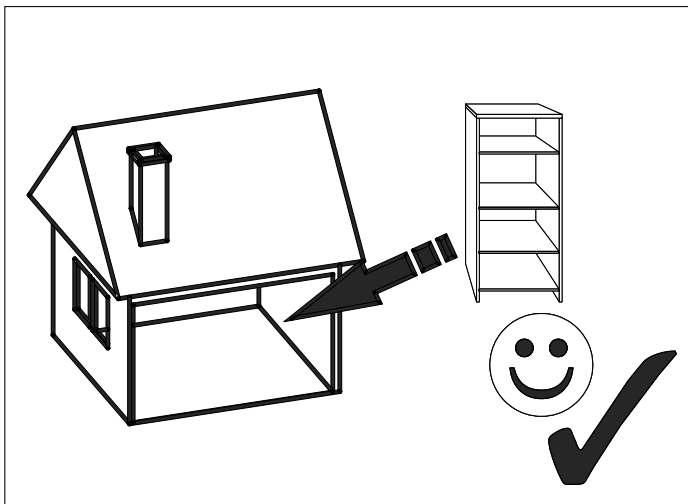

1

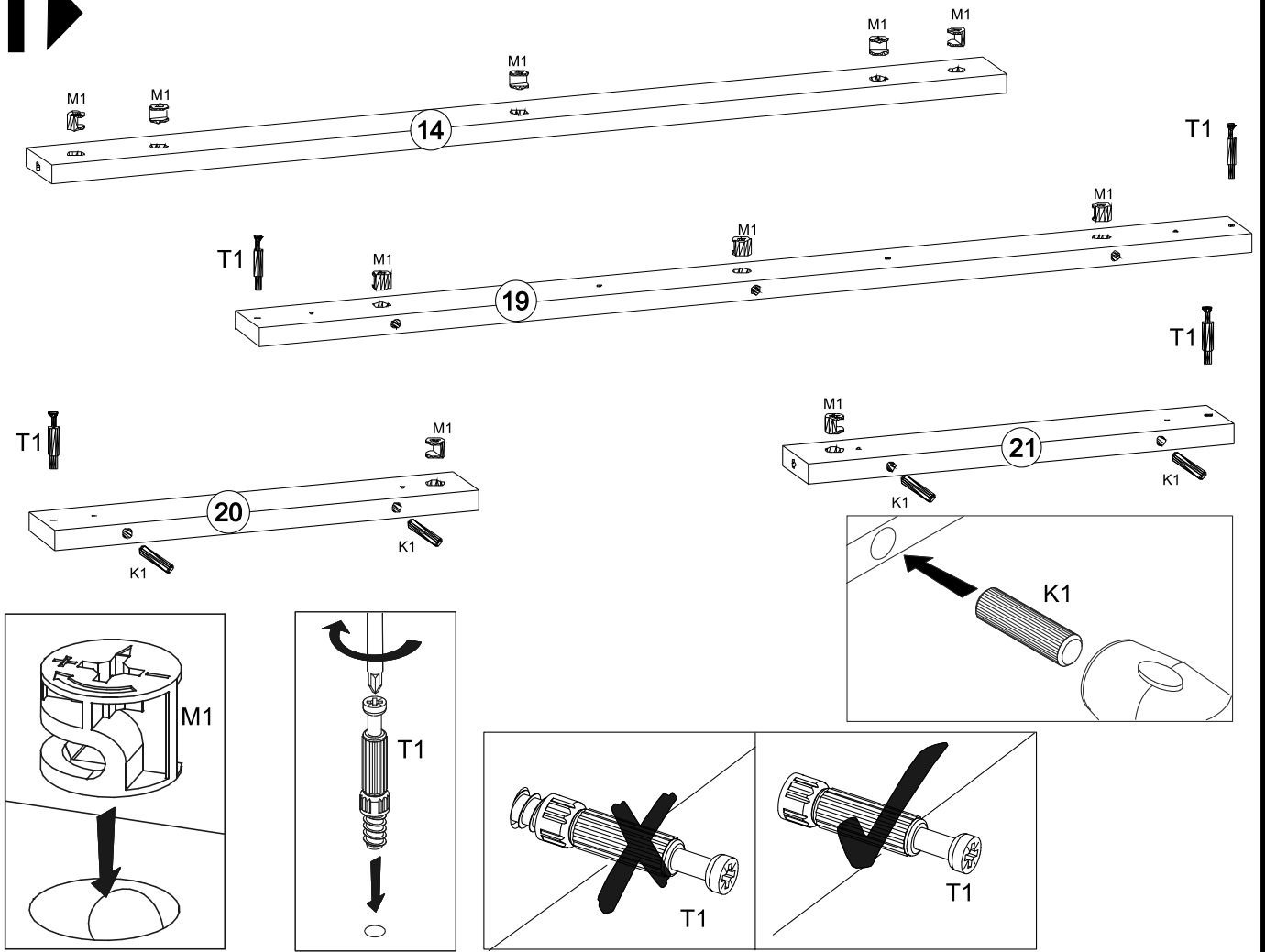

2

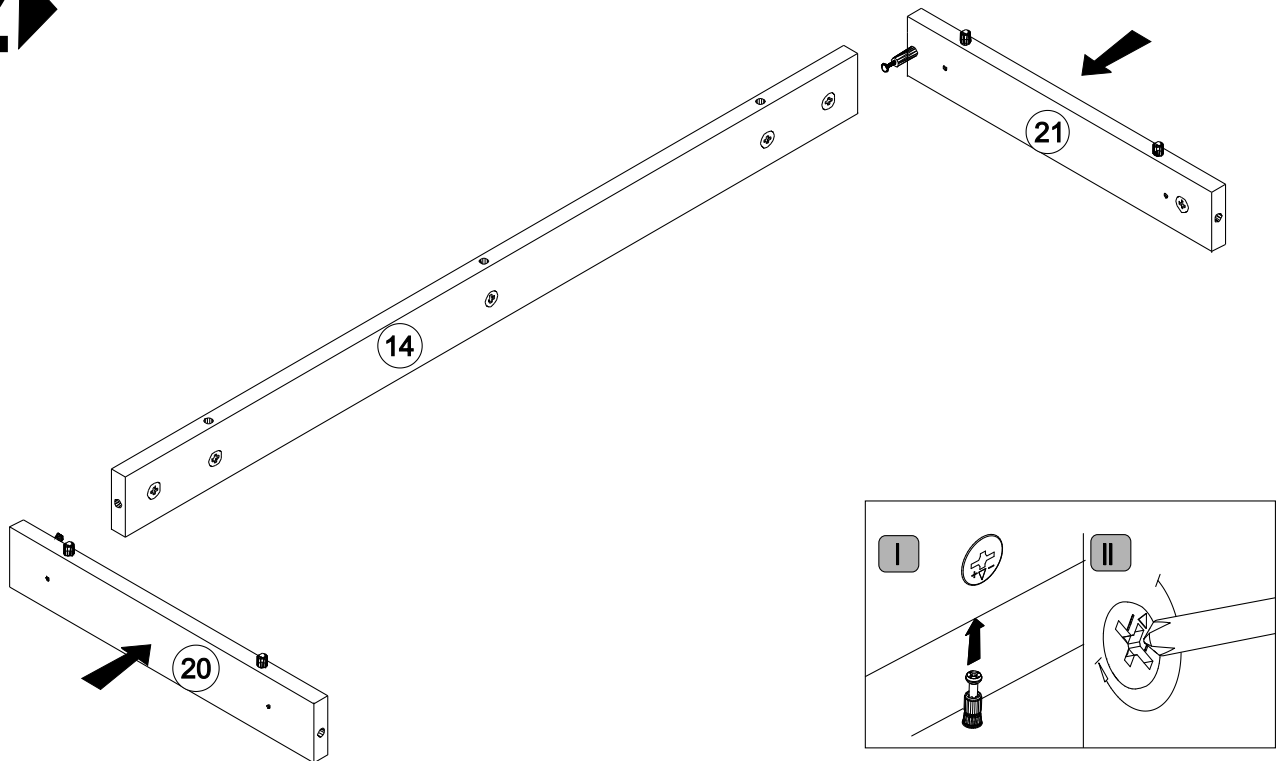

3 ➔

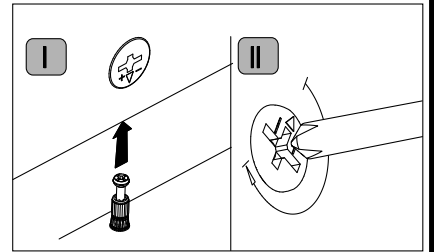
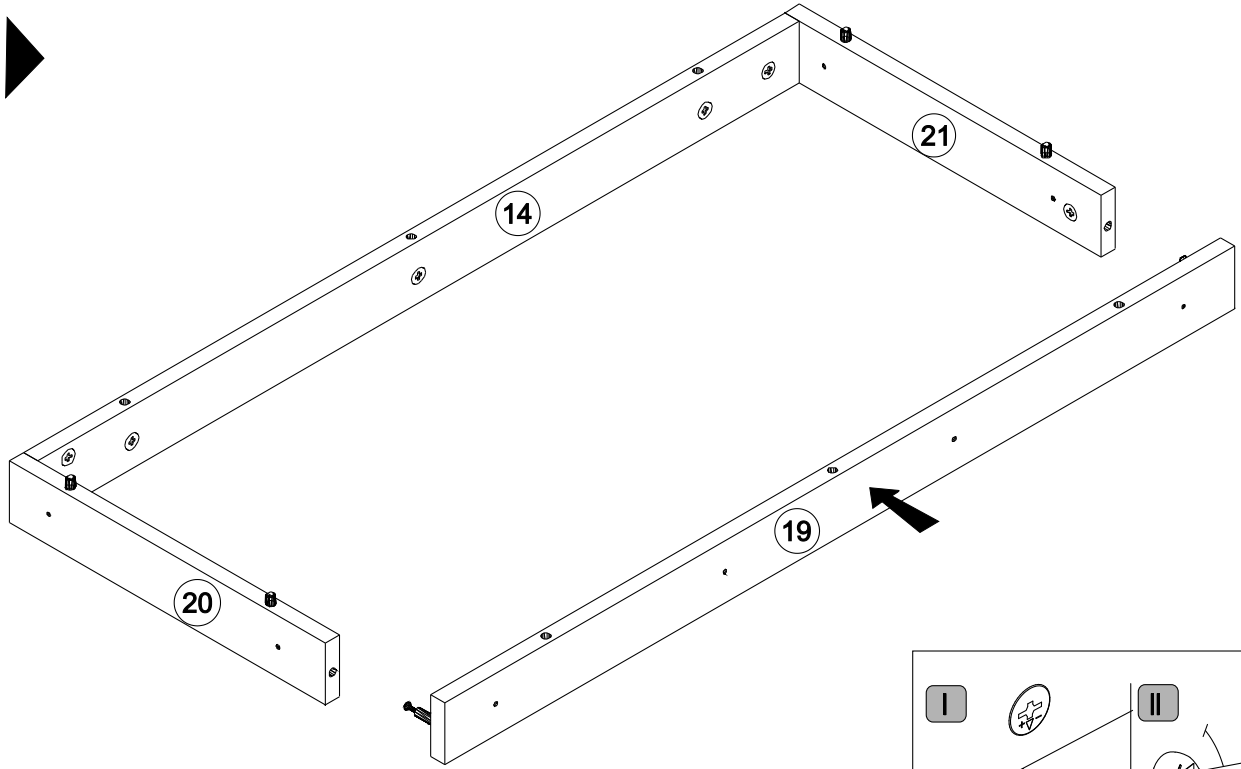

4 ➔

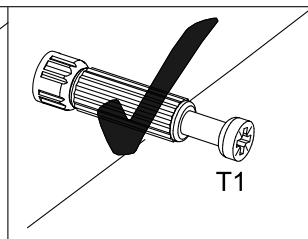
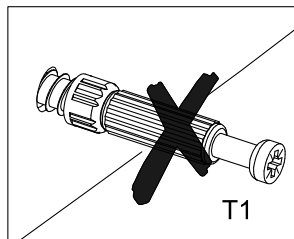
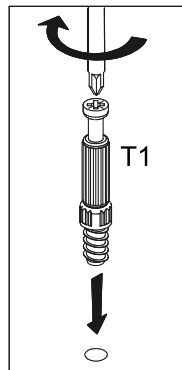
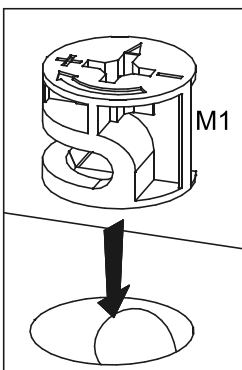
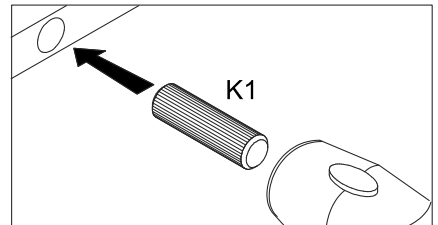
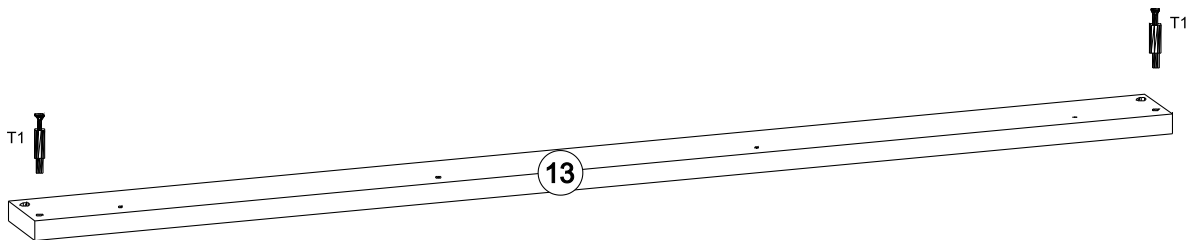

5

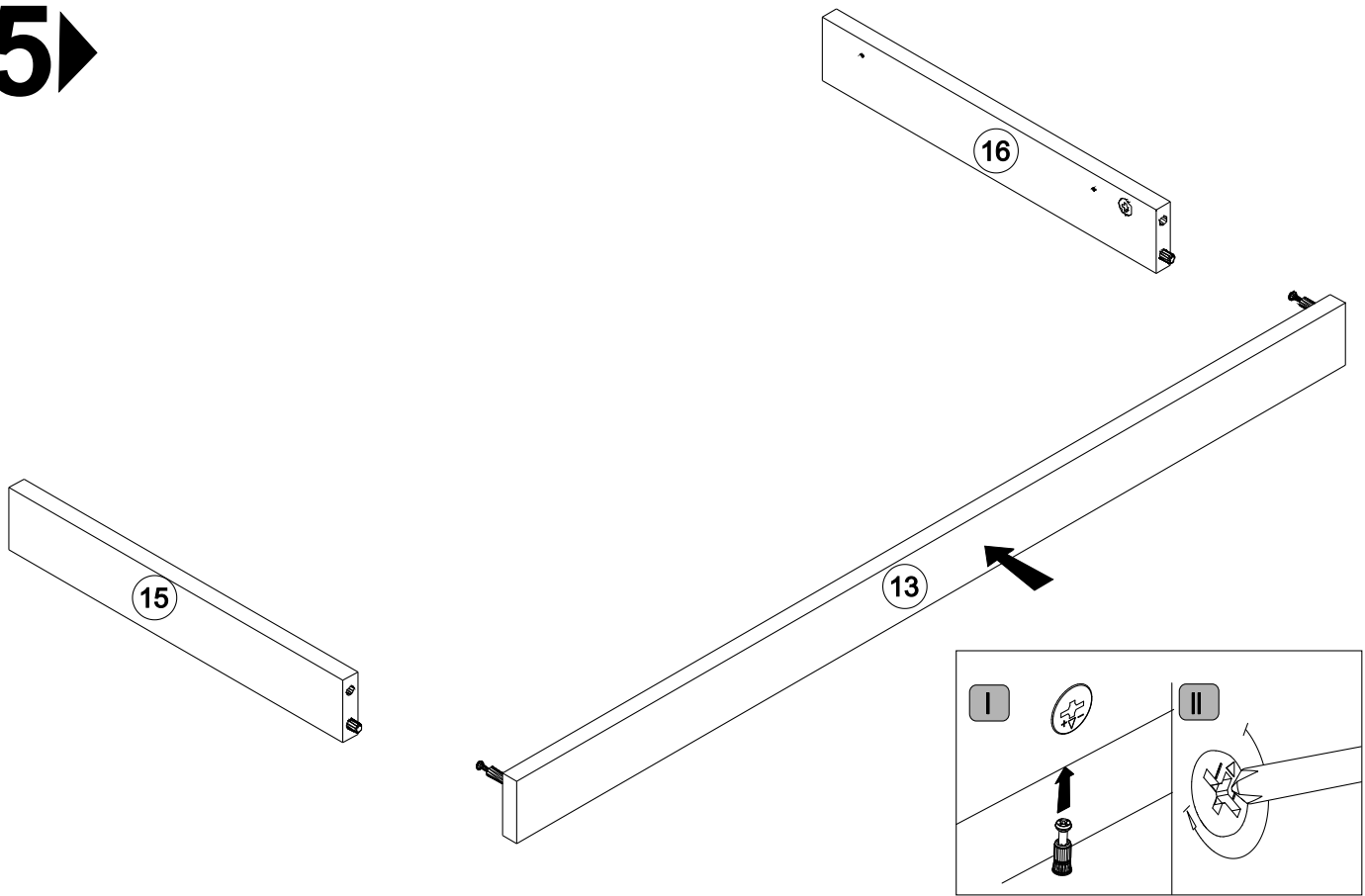

6

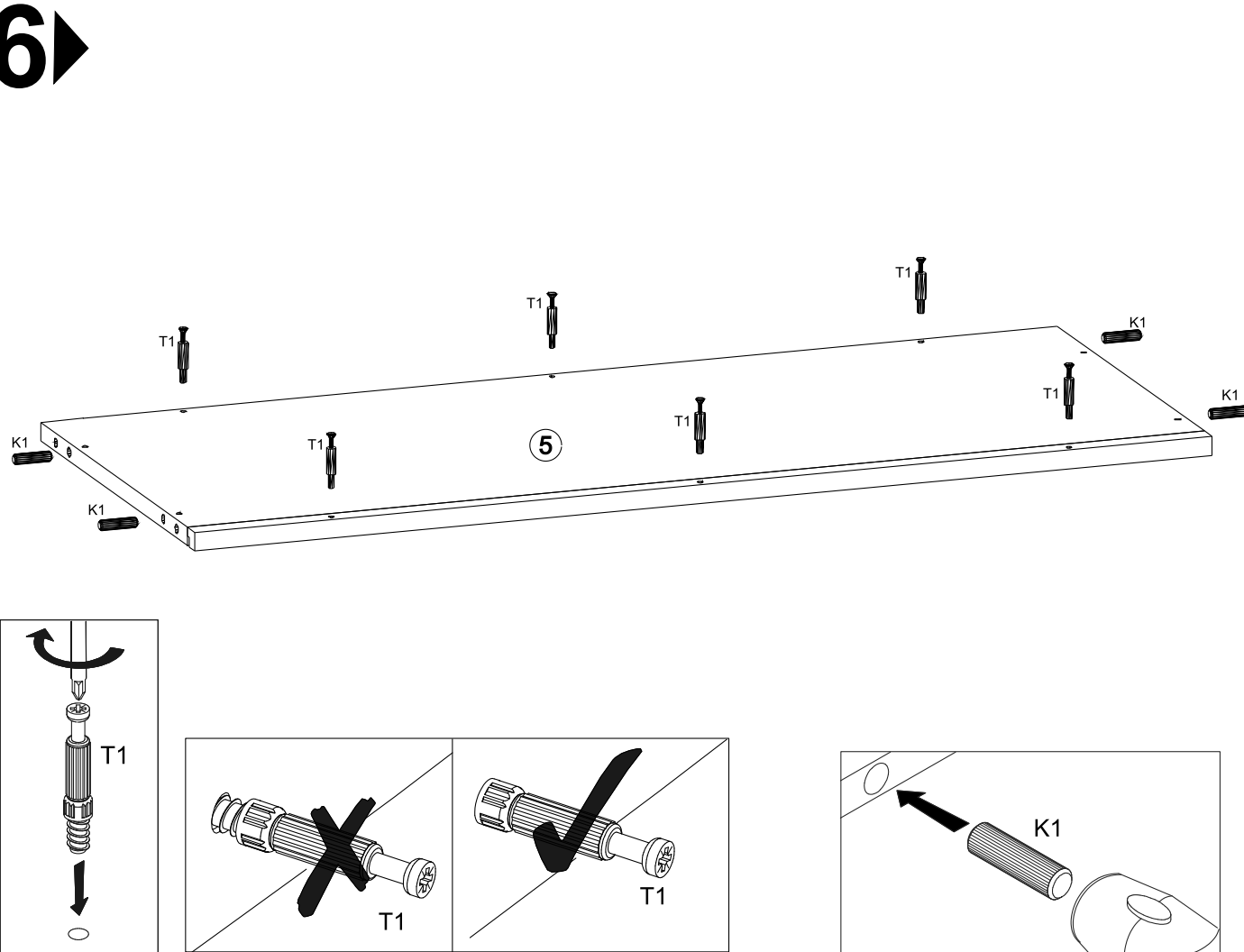

7

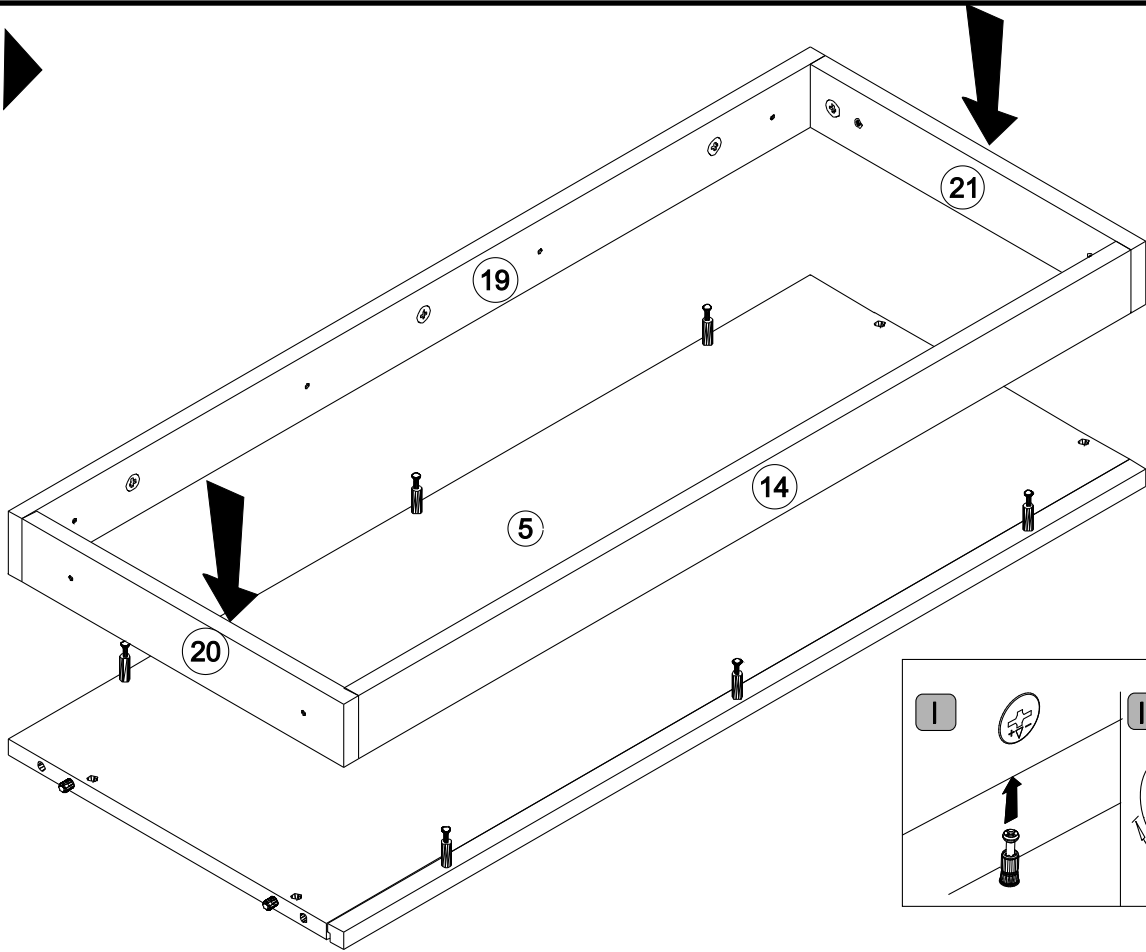

8

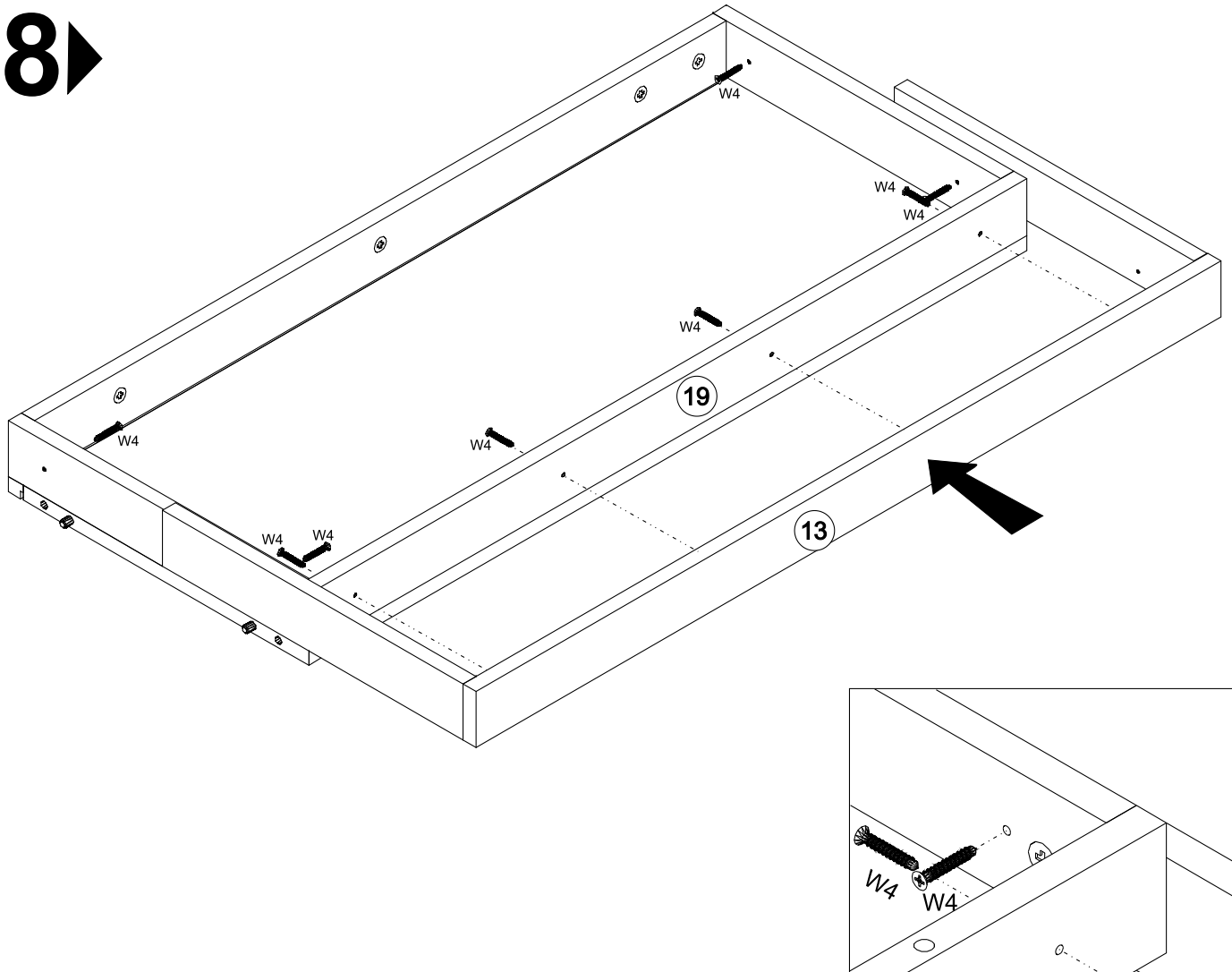

9 ▶

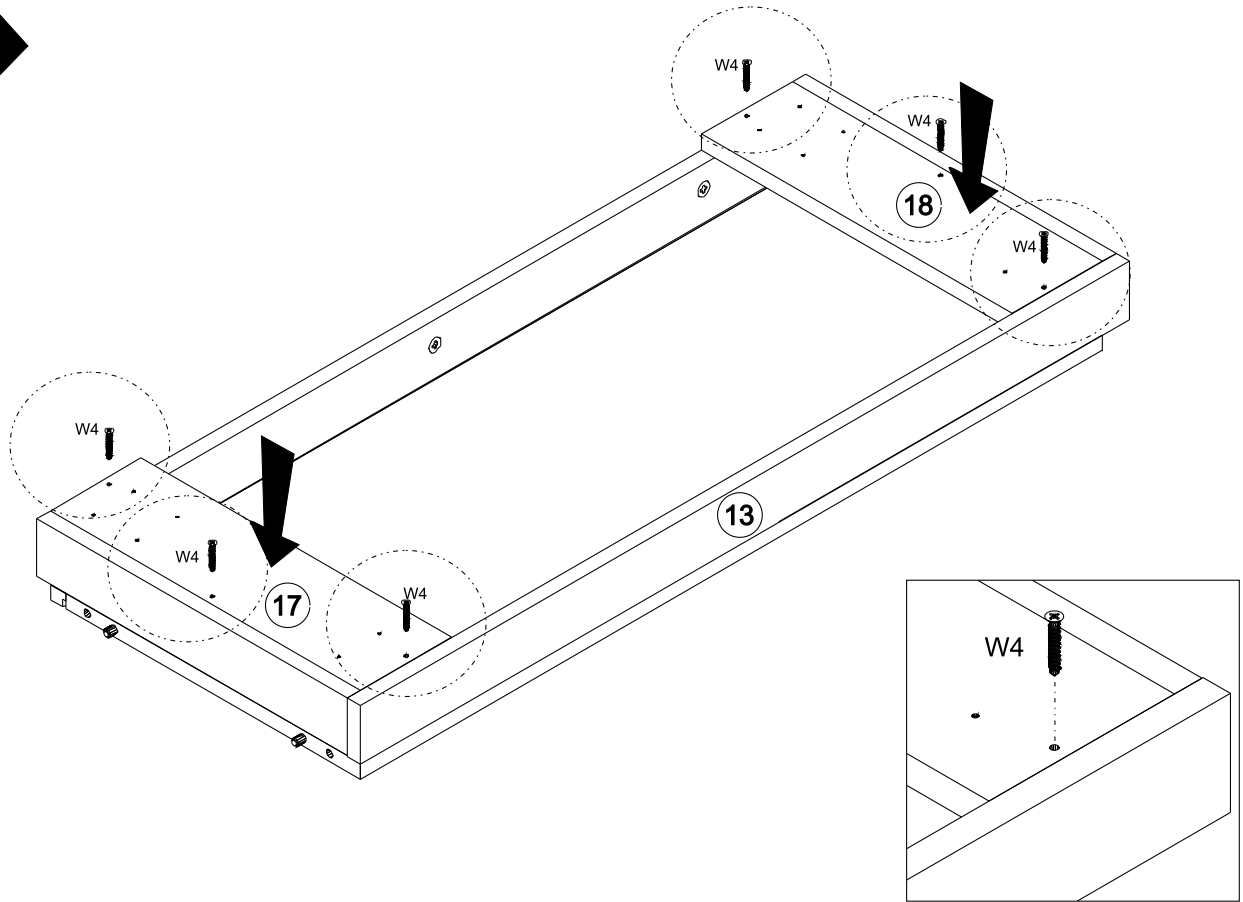

10 ▶

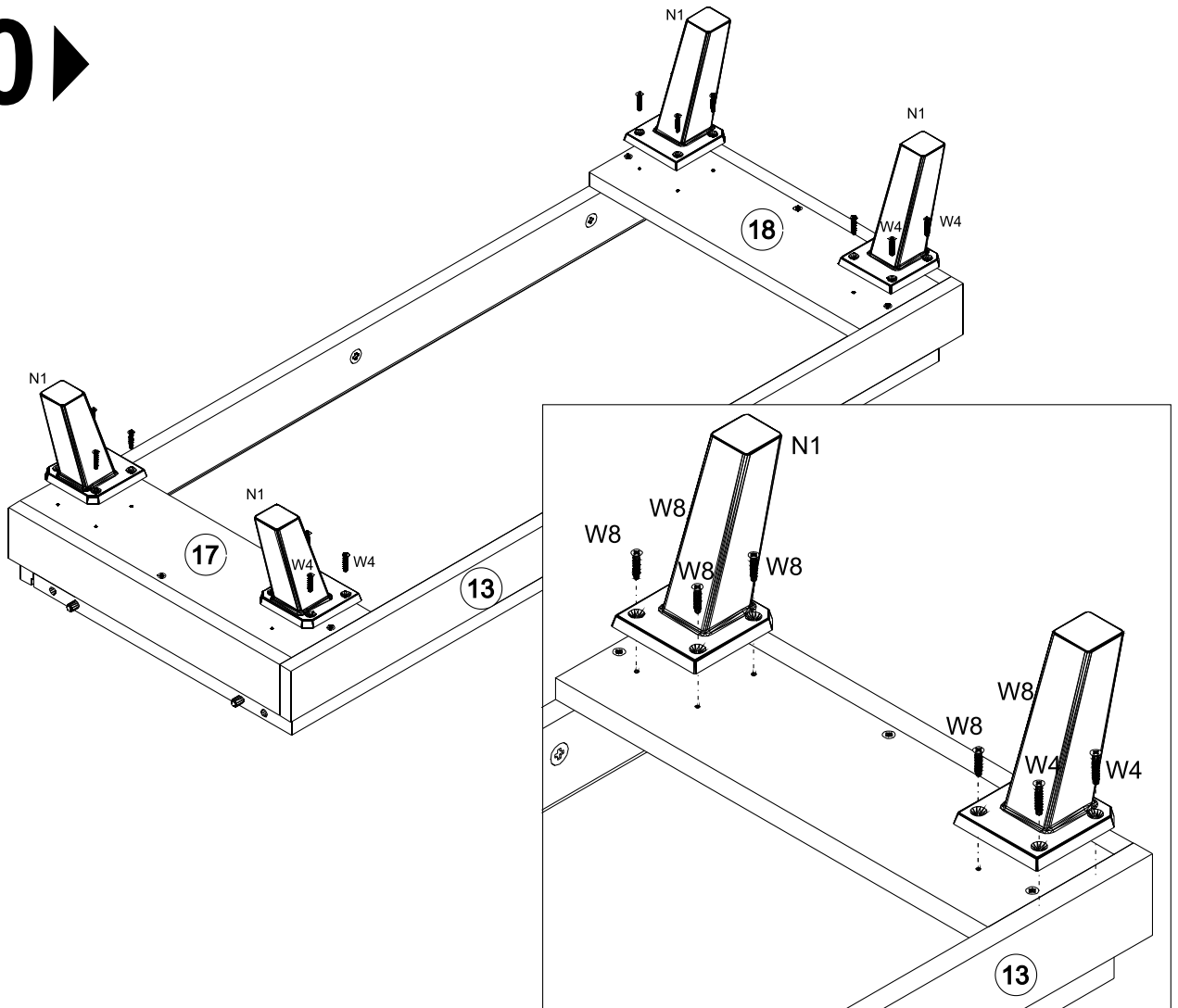

11 ▶

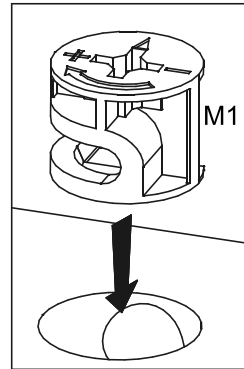
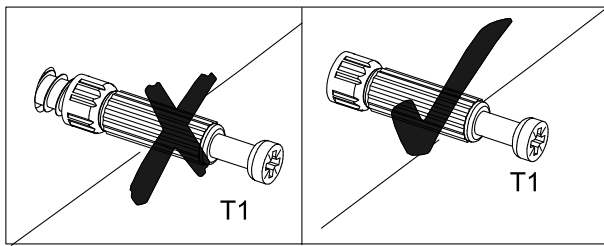
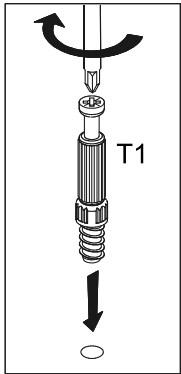
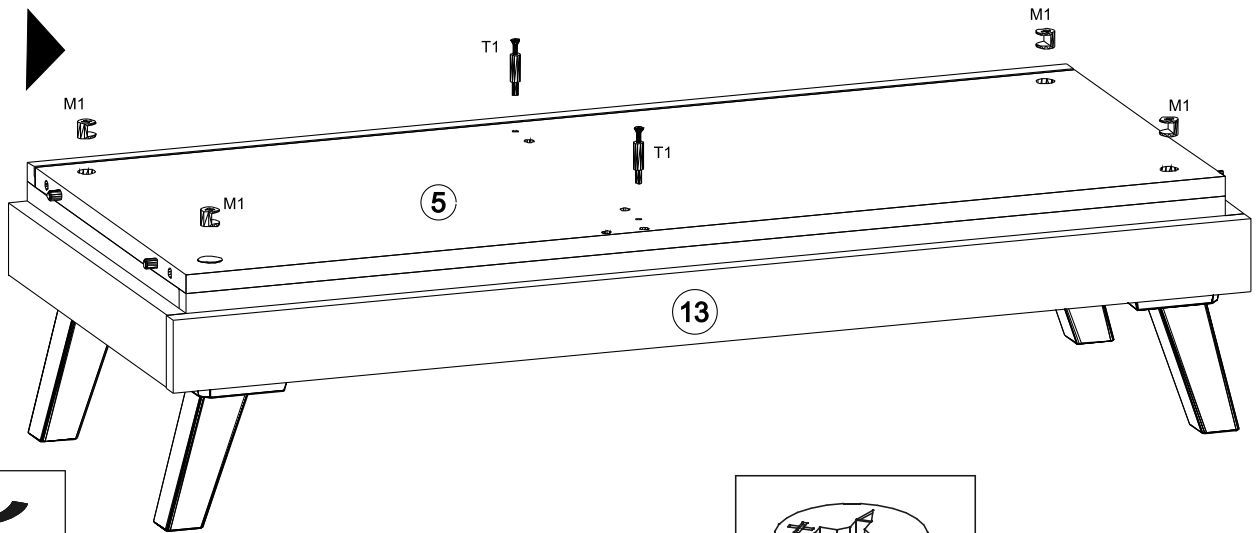

12 ▶

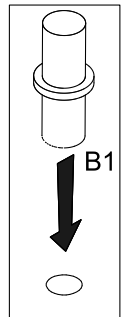
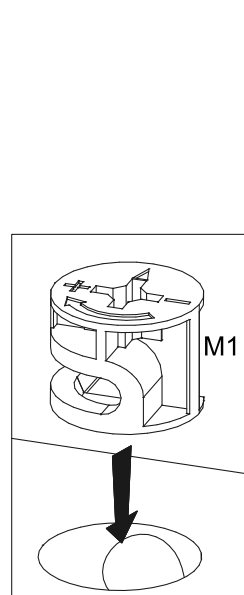
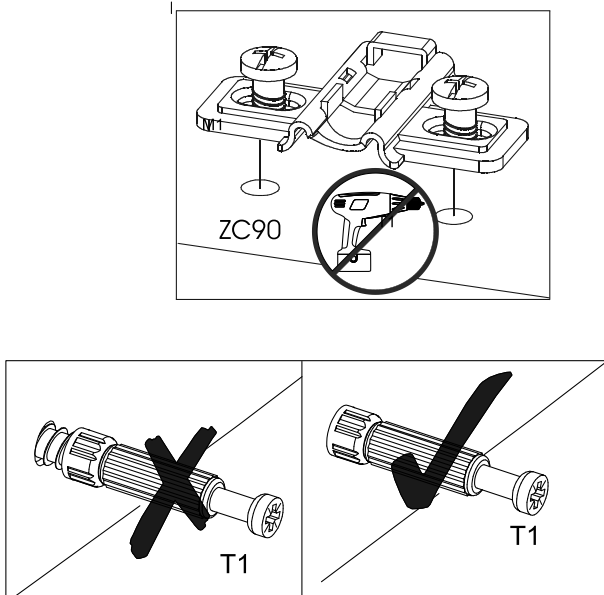
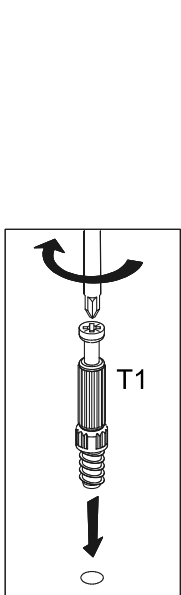
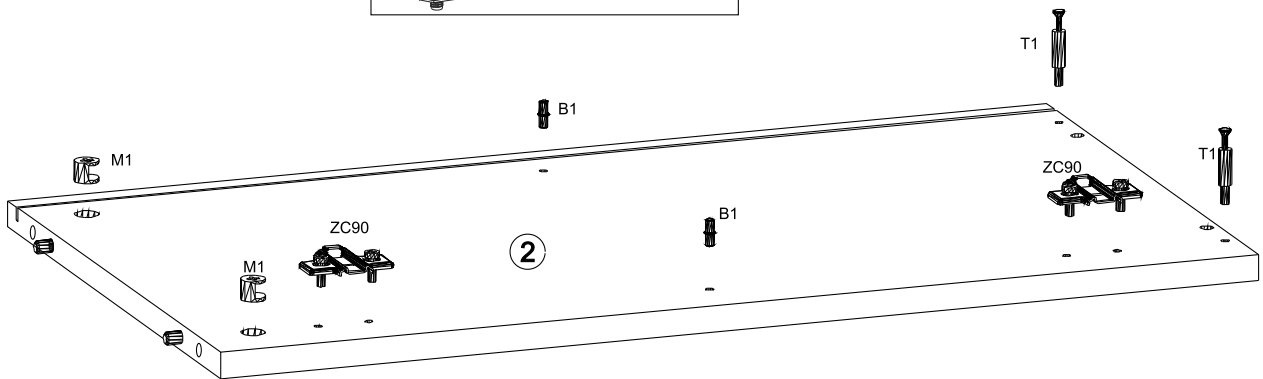
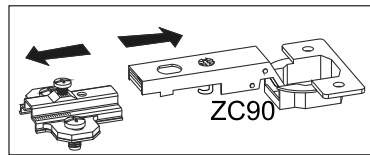

13 ▶

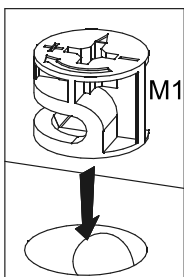
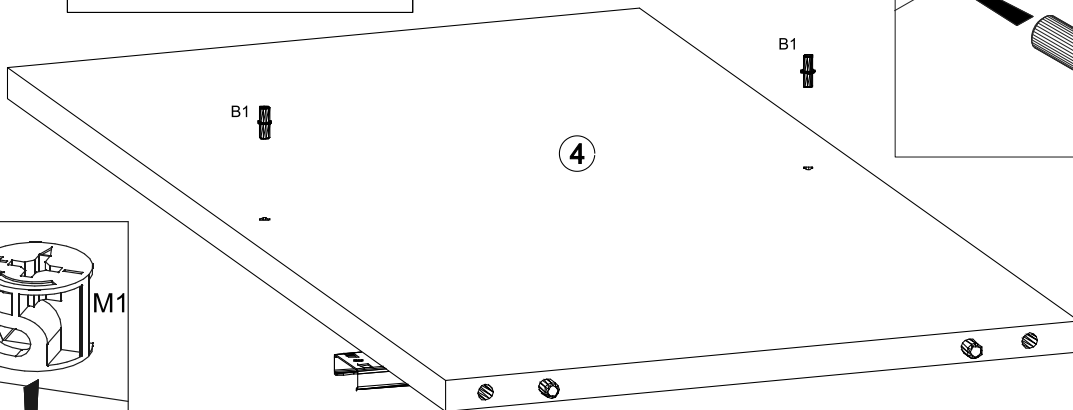
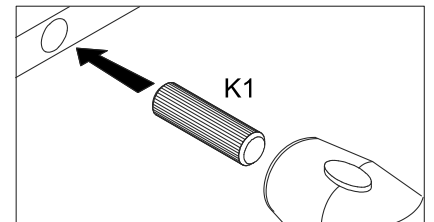
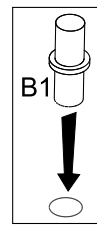
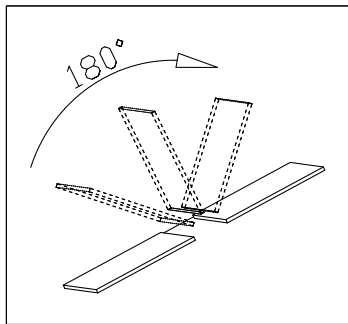
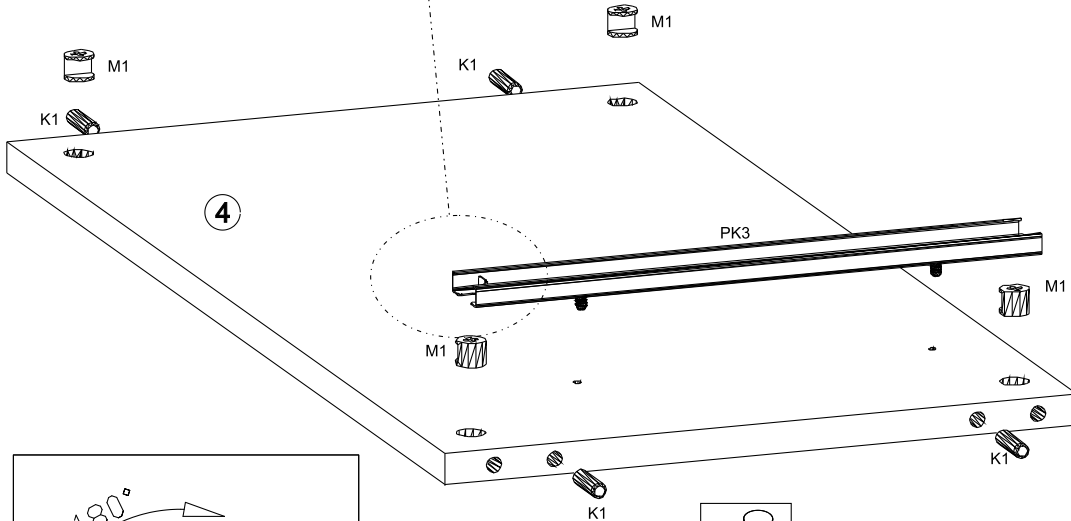
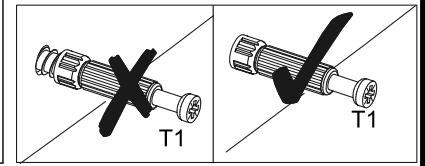
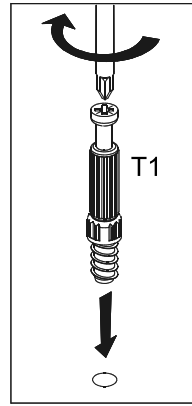
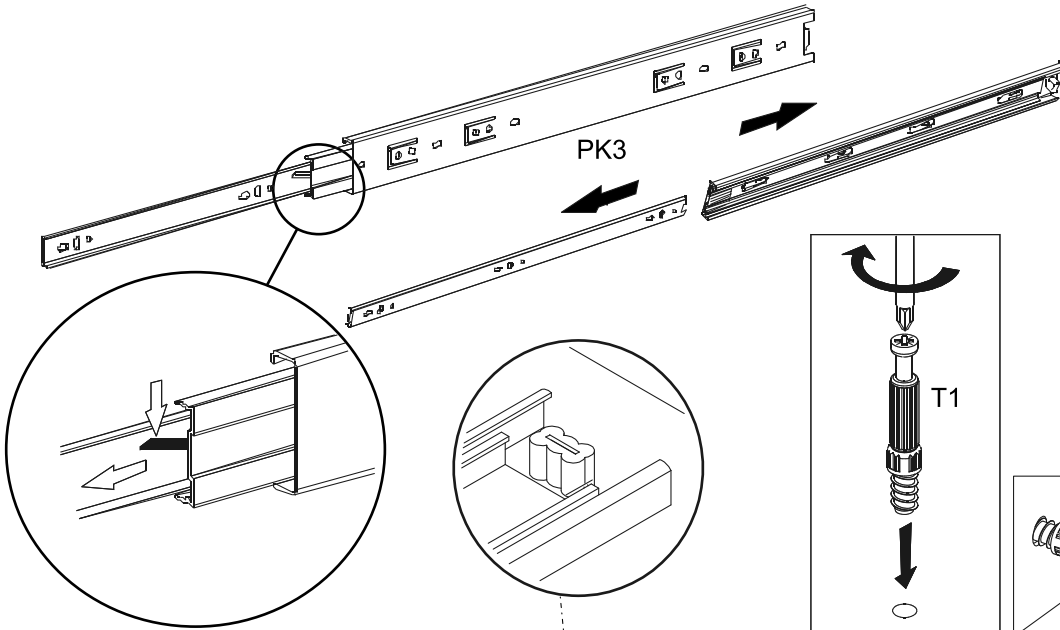
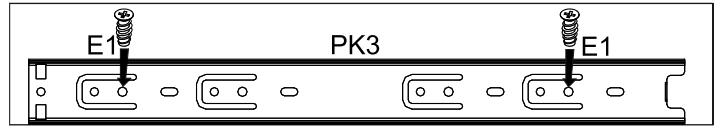

14

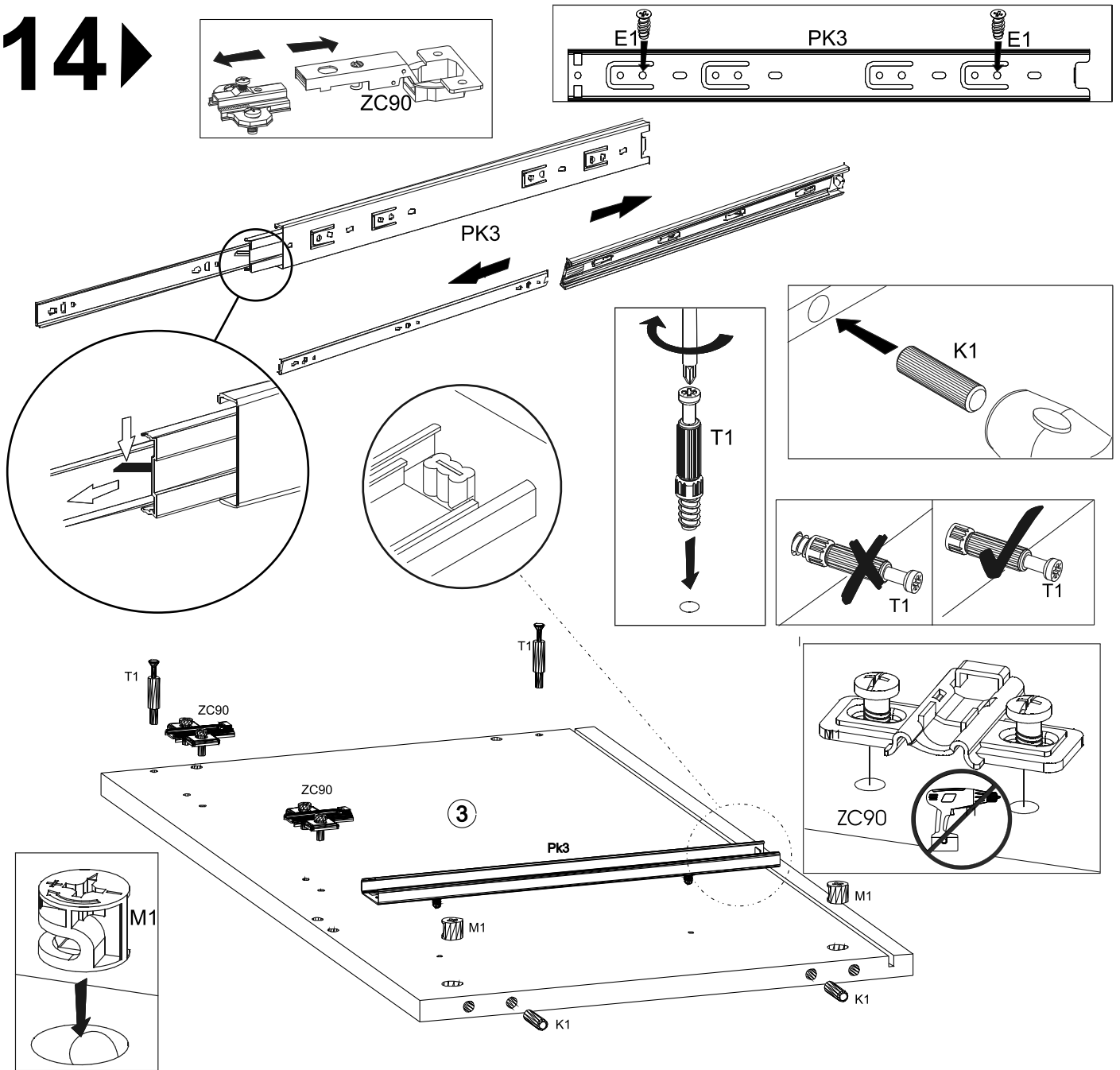

15

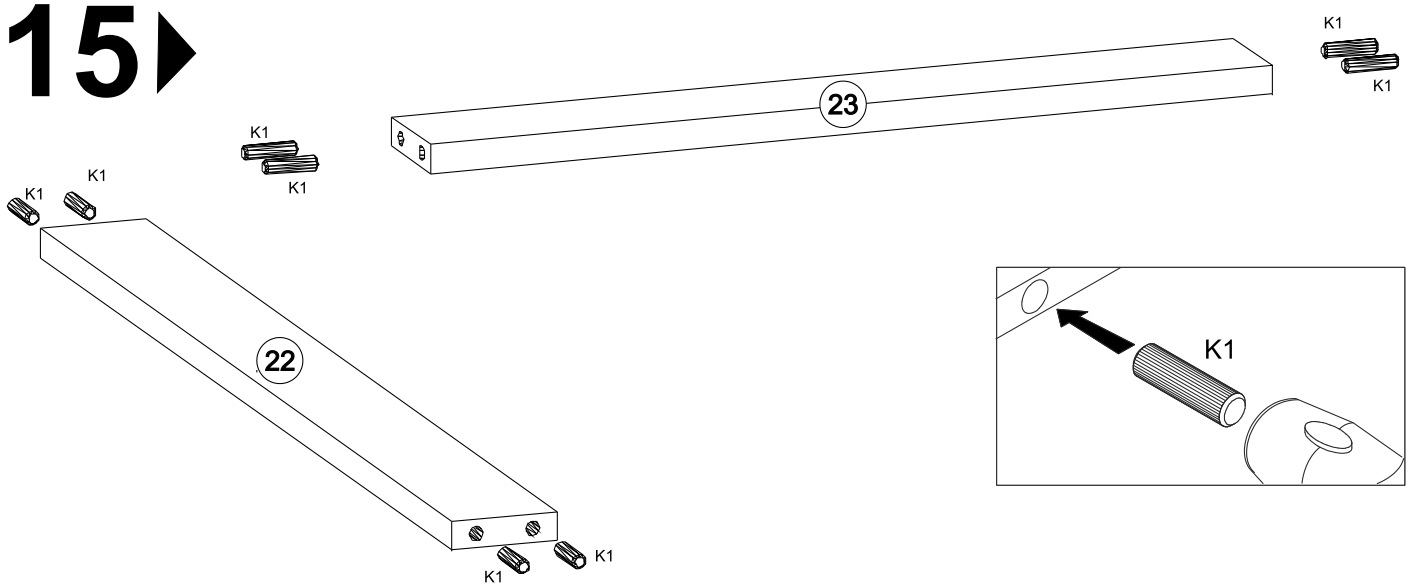

16 ▶

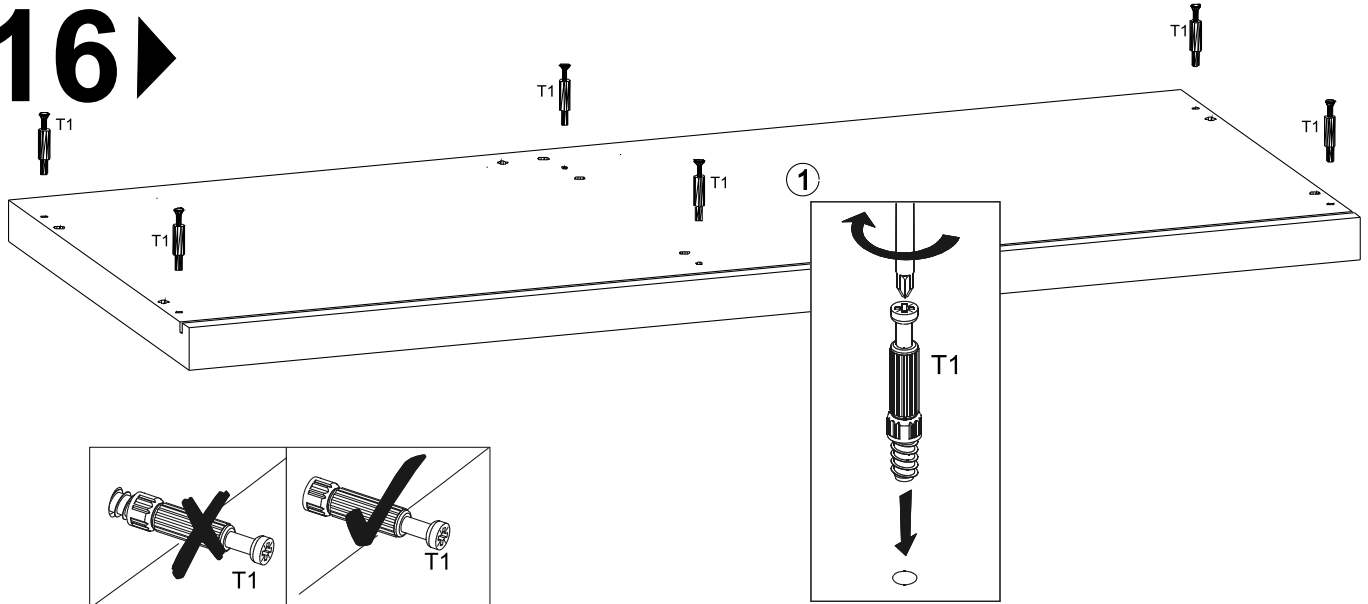

17 ▶

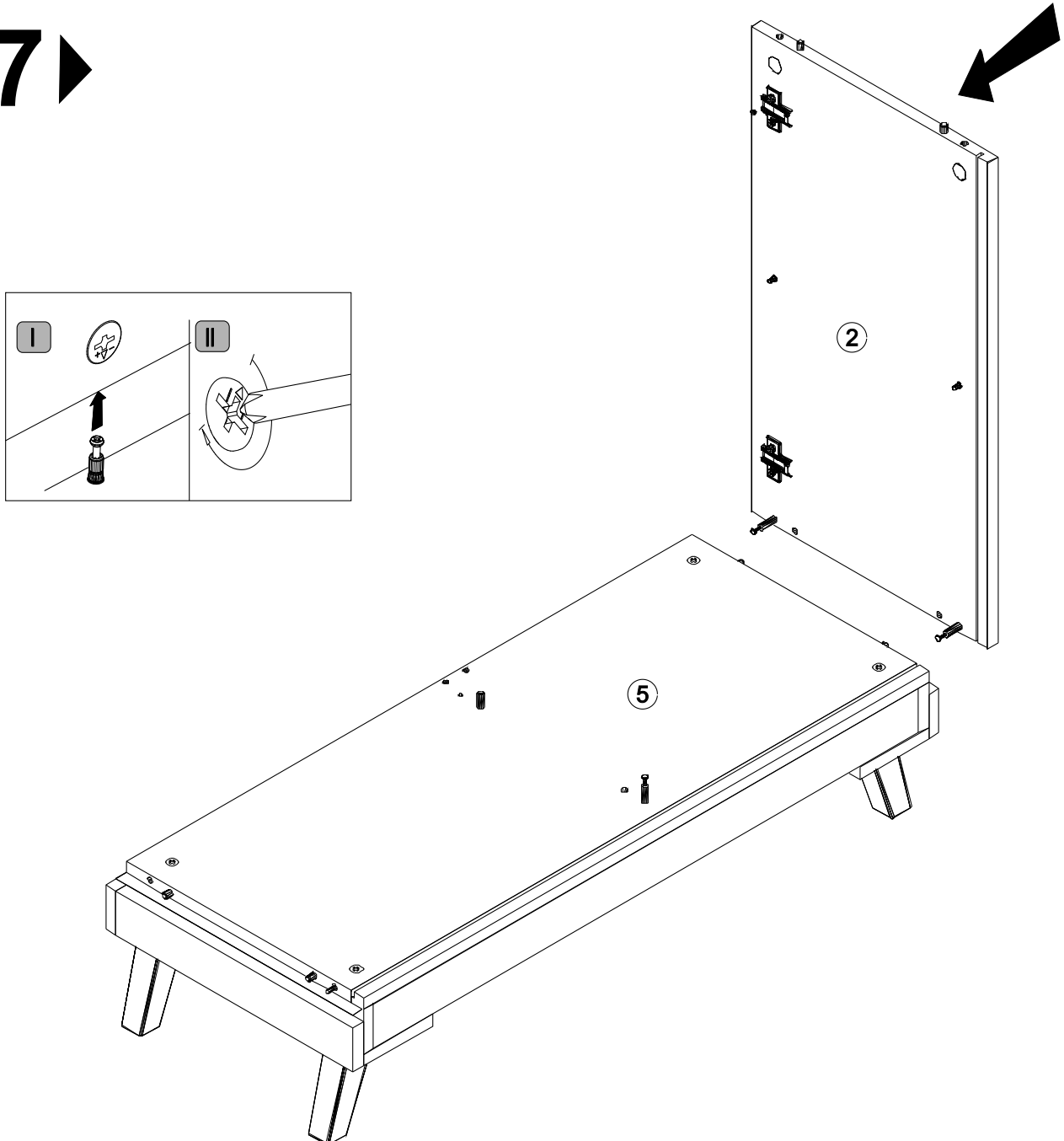

18 ▶

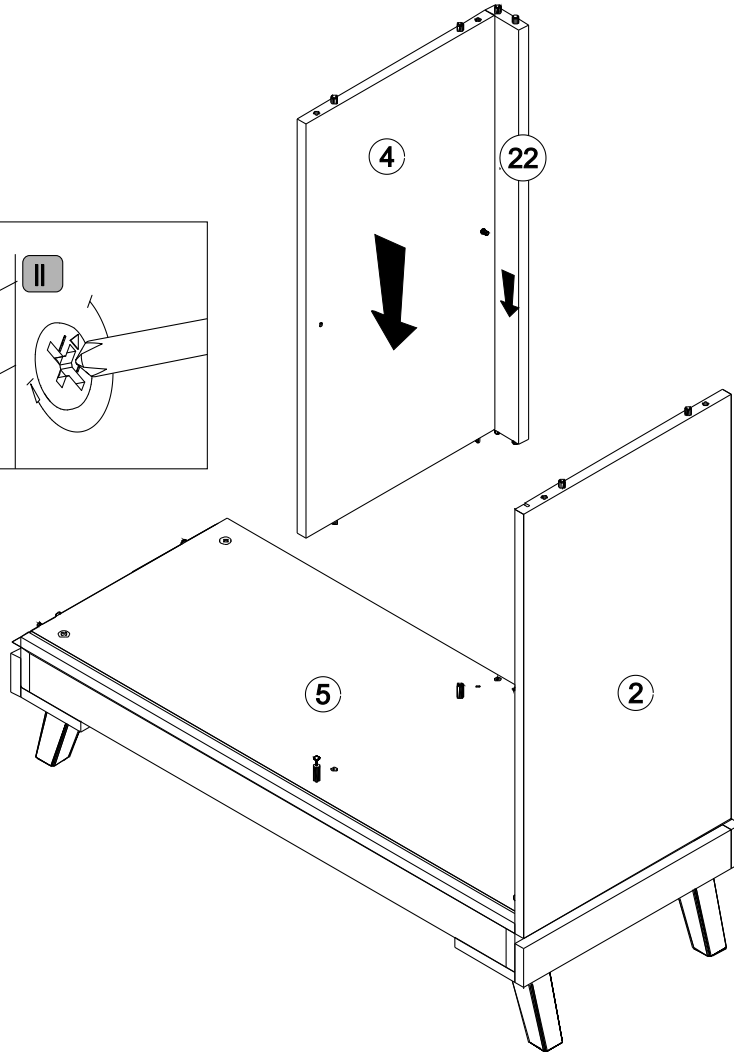
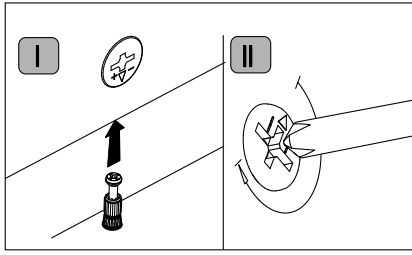

19 ▶

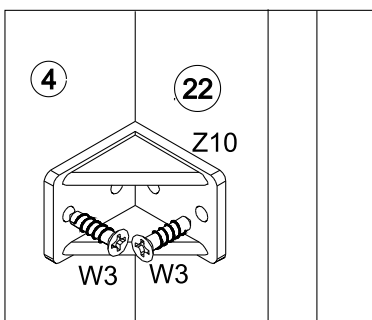
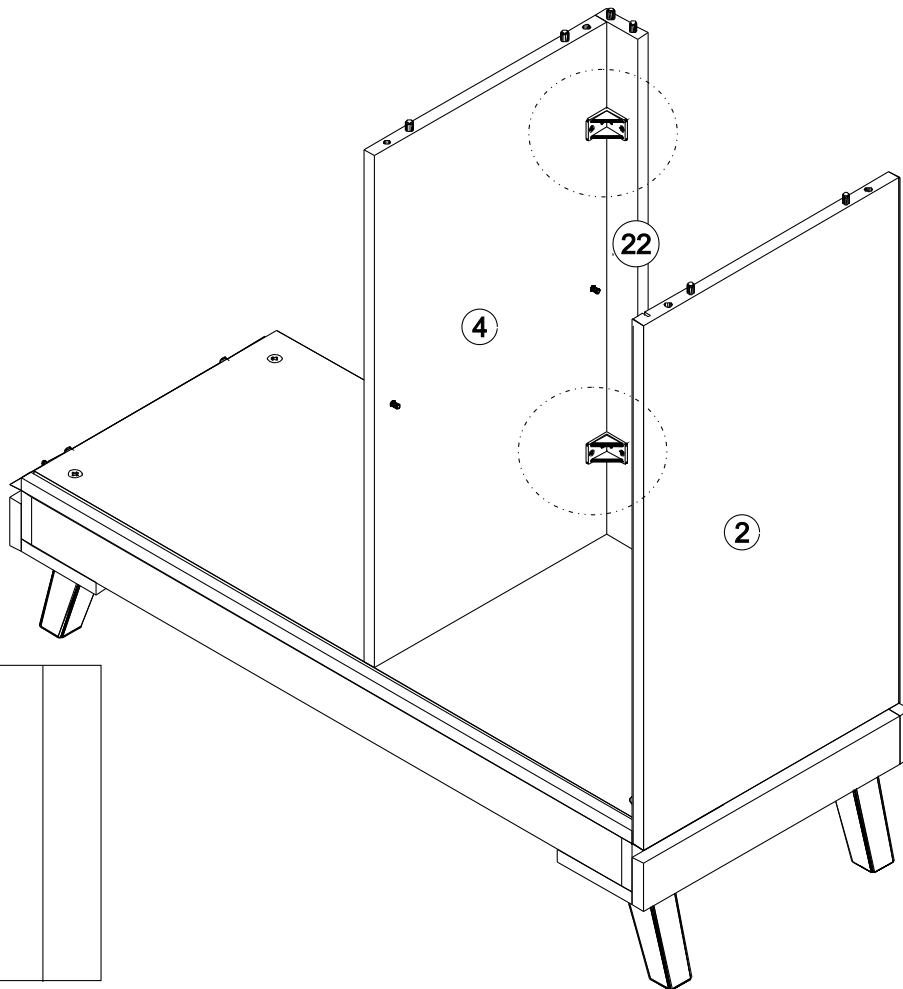

20 ▶

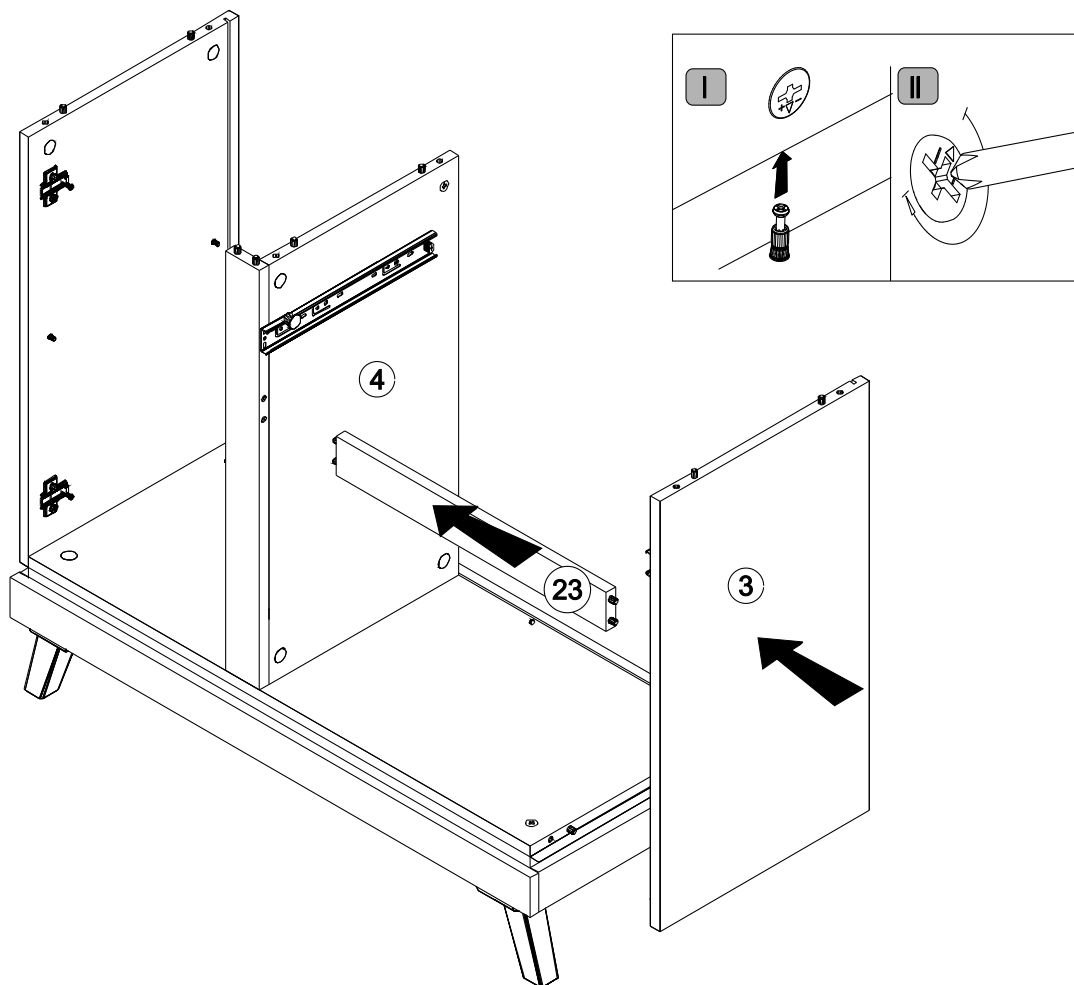

21 ▶

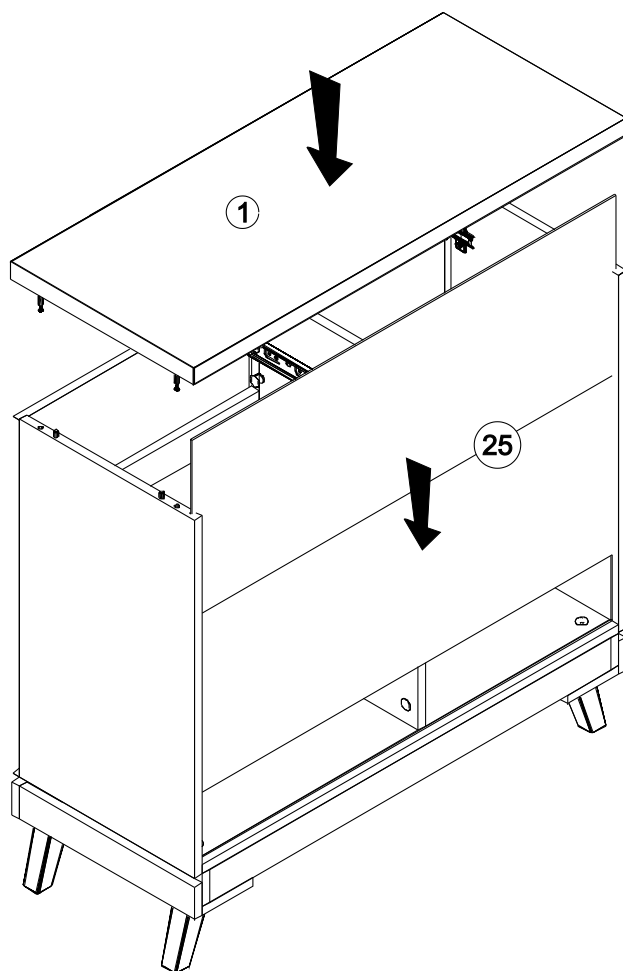

22 ▶

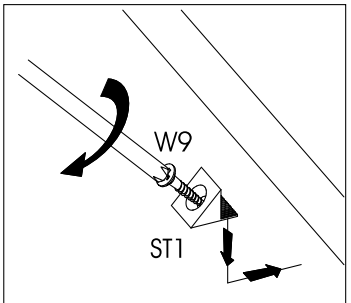
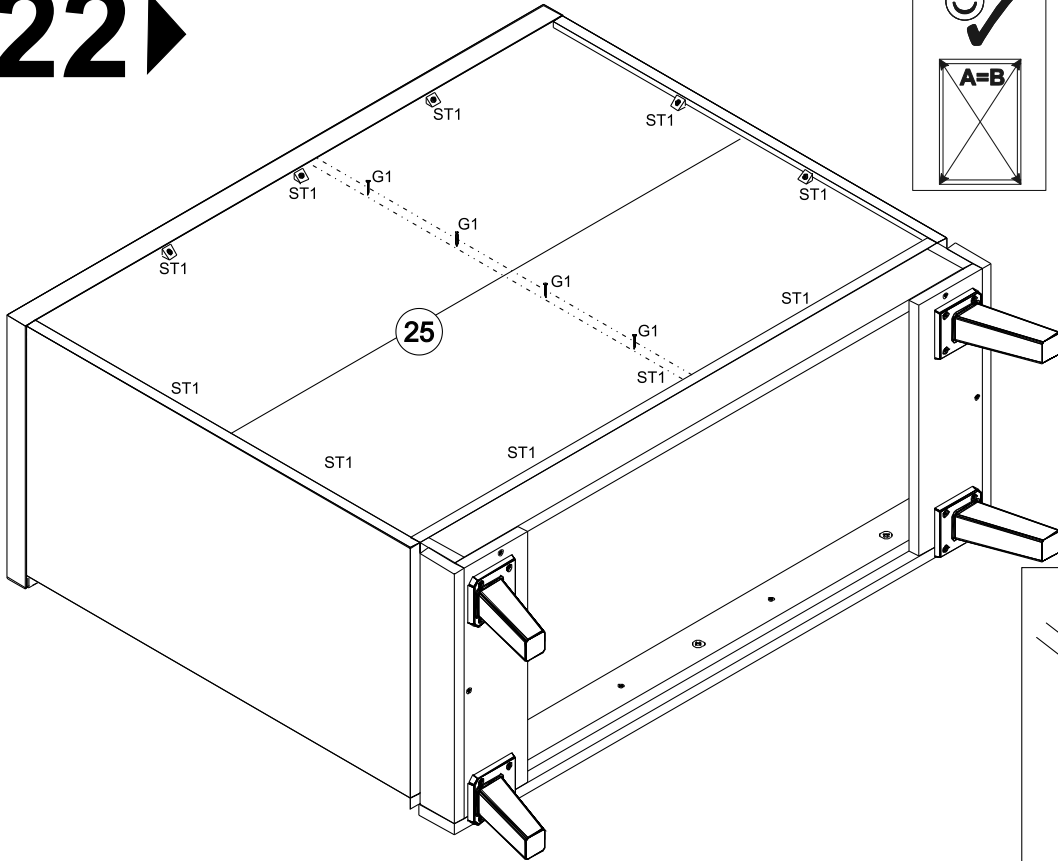

23 ▶

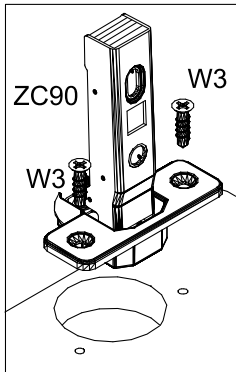
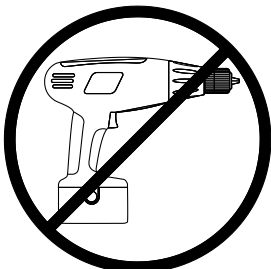
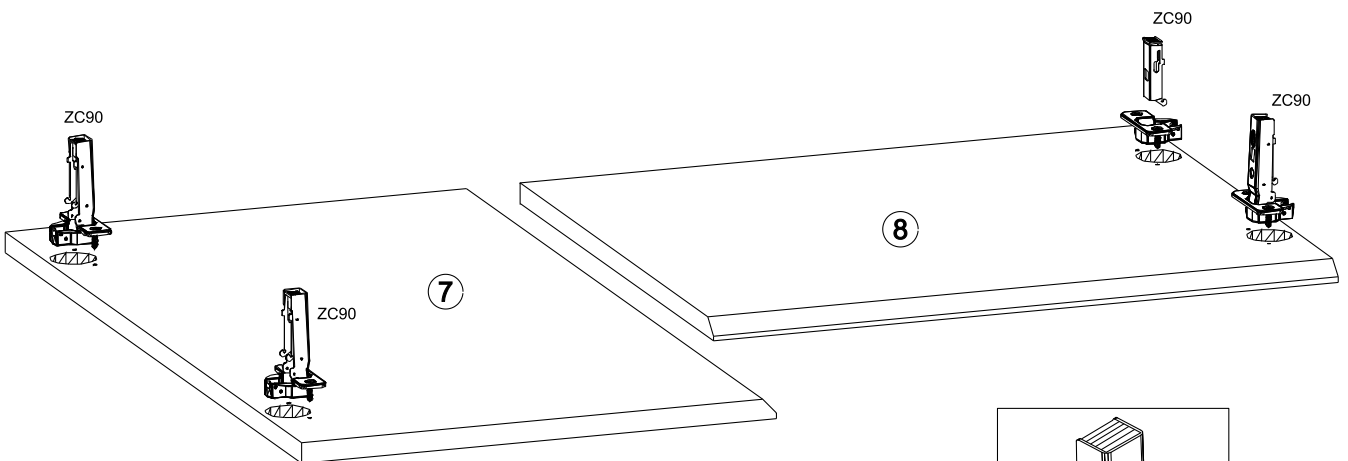

24 ▶

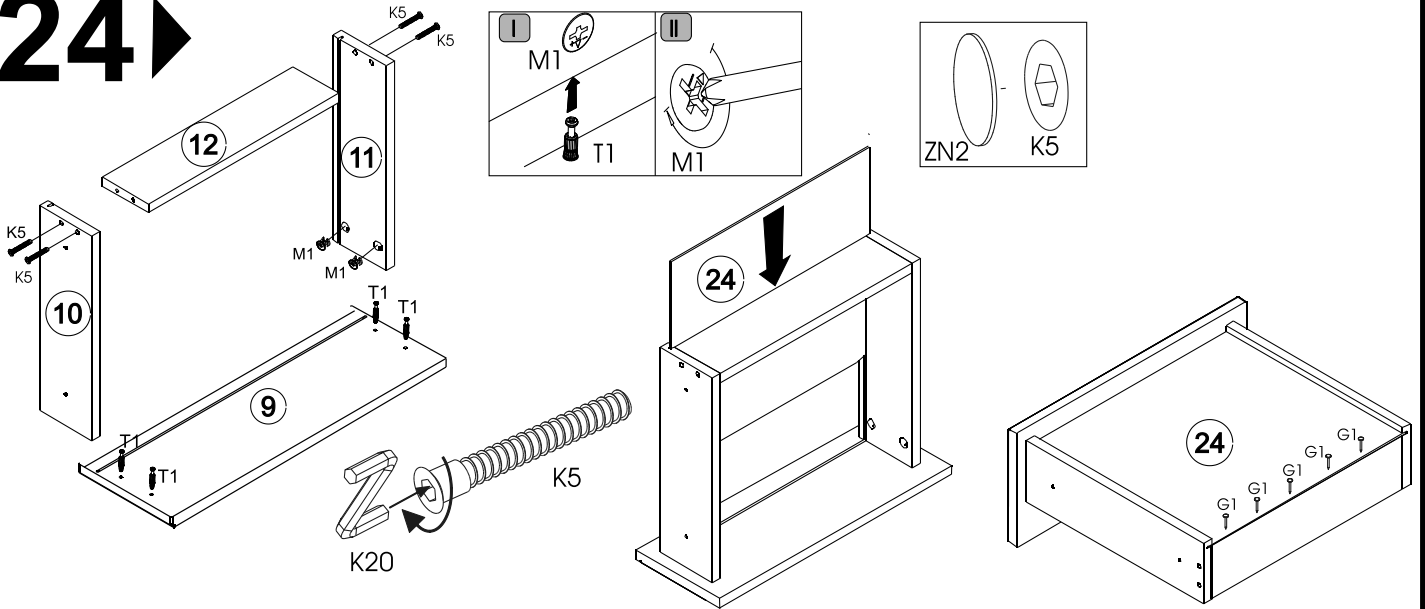

25 ▶

