

MODELL: ATO 1

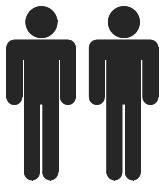

625

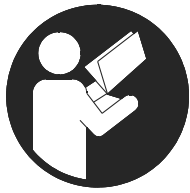
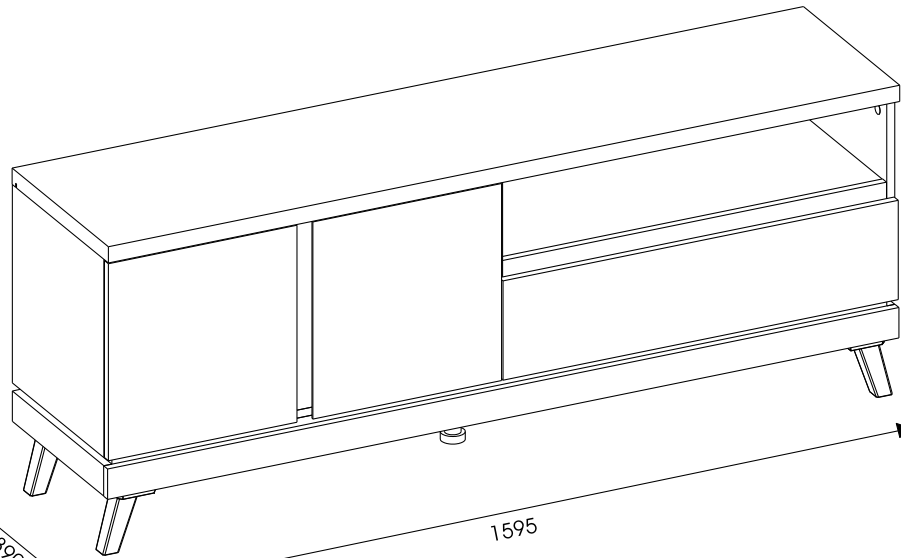

390

1595

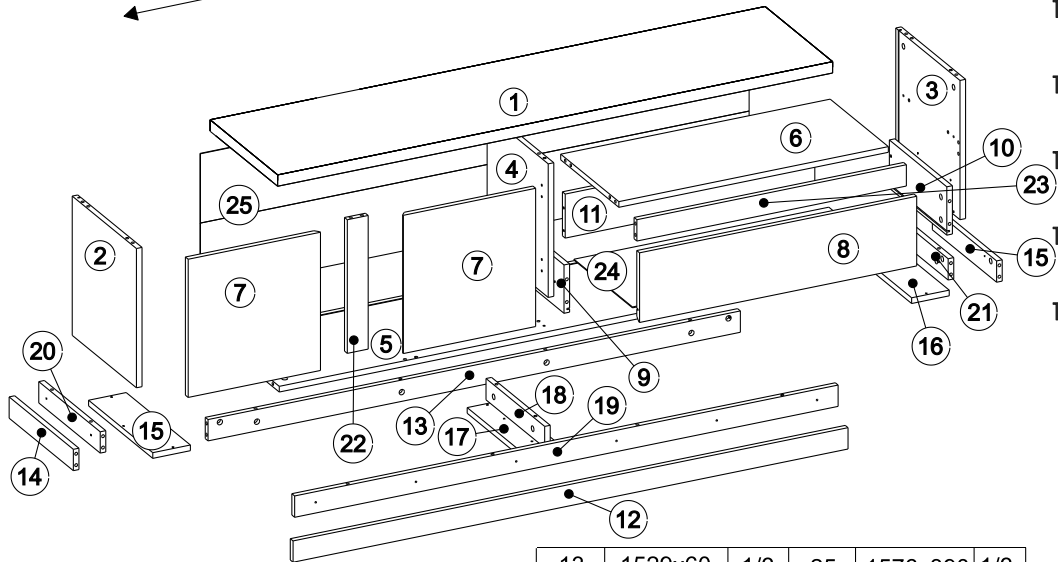
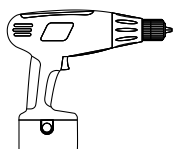
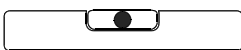
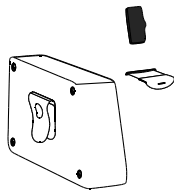
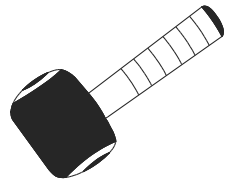
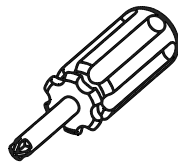
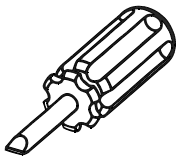
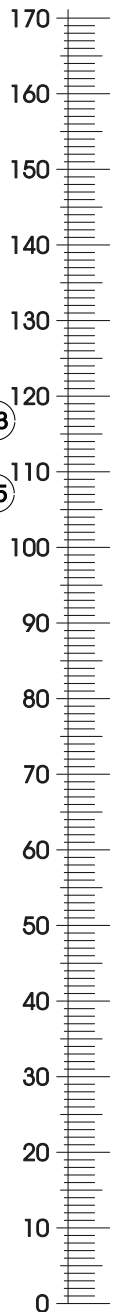

13	1529x60	1/3	25	1576x390	1/3
12	1594x60	1/3	24	336x732	1/3
11	717x124	2/3	23	774x60	1/3
10	330x136	2/3	22	376x60	1/3
9	330x136	2/3	21	353x60	1/3
8	796x196	2/3	20	353x60	1/3
7	389x380	2/3	19	1561x60	1/3
6	774x334	2/3	18	337x60	1/3
5	1561x369	1/3	17	369x108	1/2
4	376x351	2/3	16	369x108	1/2
3	392x369	2/3	15	369x60	1/3
2	392x369	2/3	15	369x108	1/2
1	1595x388	1/3	14	369x60	1/3

12x #20/981 ZN1	12x 3.5x16 W3	11x ST1	1 kpl. #300 PK3	1x N2	11x 3x20 W9	2x ZC8	21x 4x30 W4	4x N1
4x 6.4x50 K5	32x 8x30 K1	2x ZC90	1x K20	34x #15/15 M1	34x DU232T T1	12x 3.5x20 W8	10x 2x20 G1	8x 5x11 E1

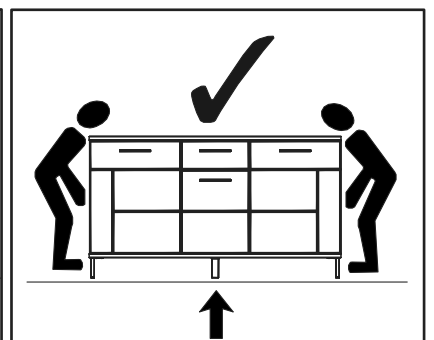
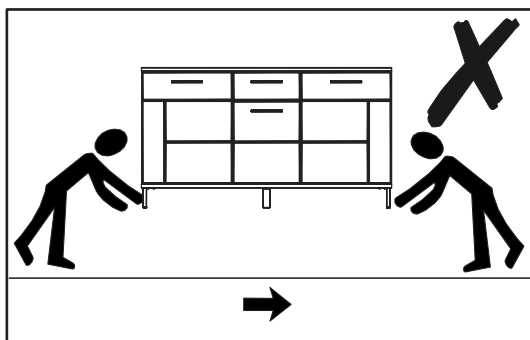
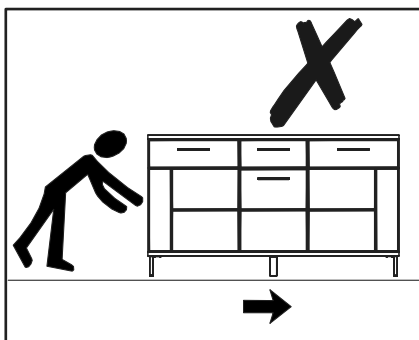
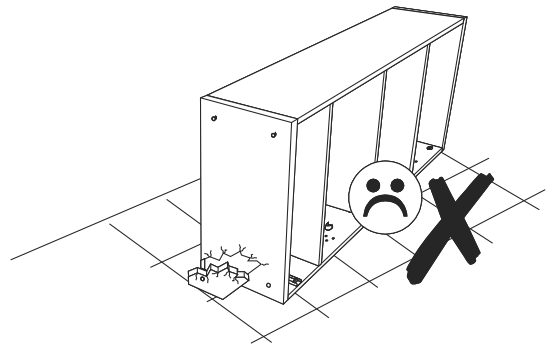
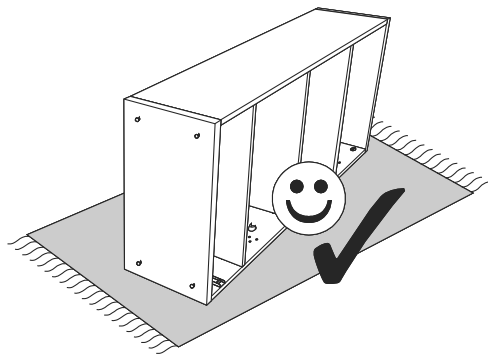
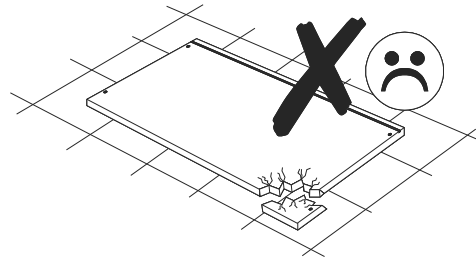
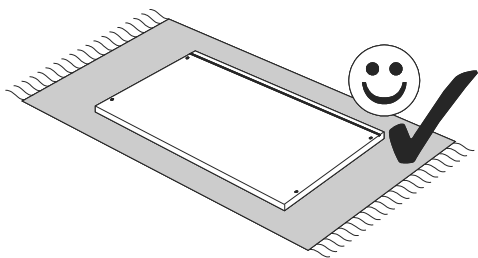
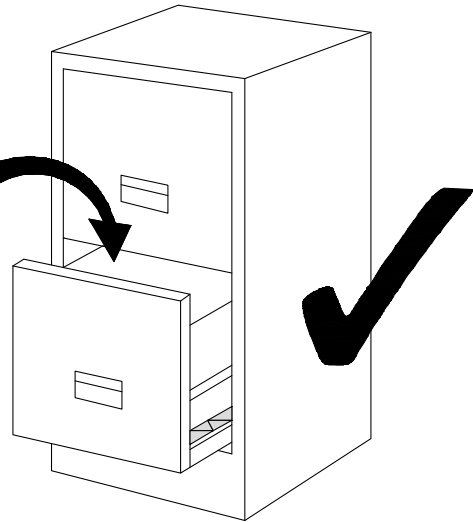
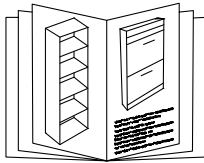
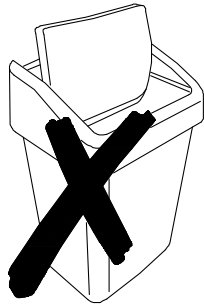

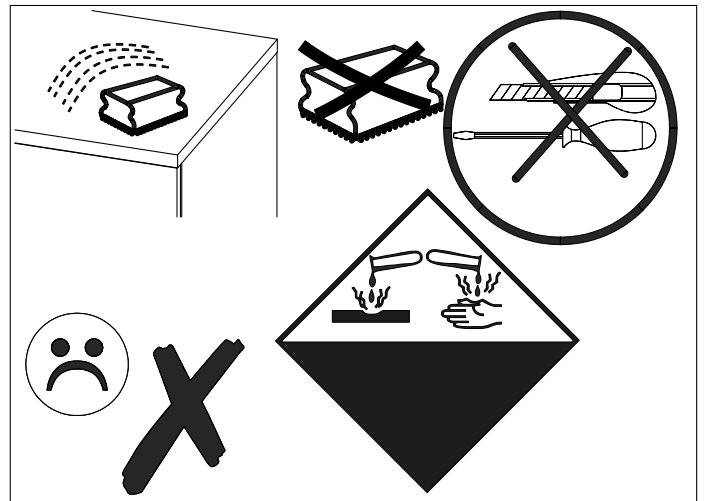
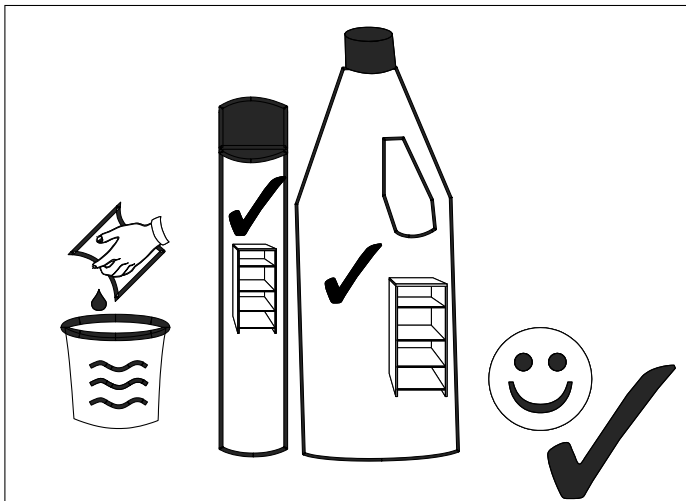
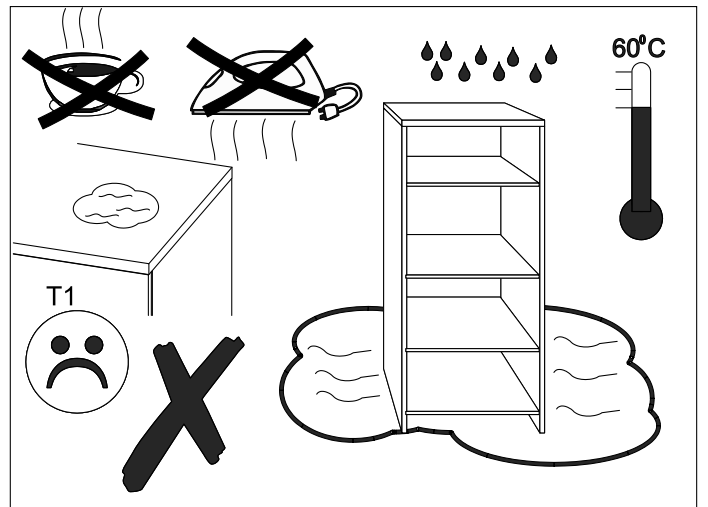
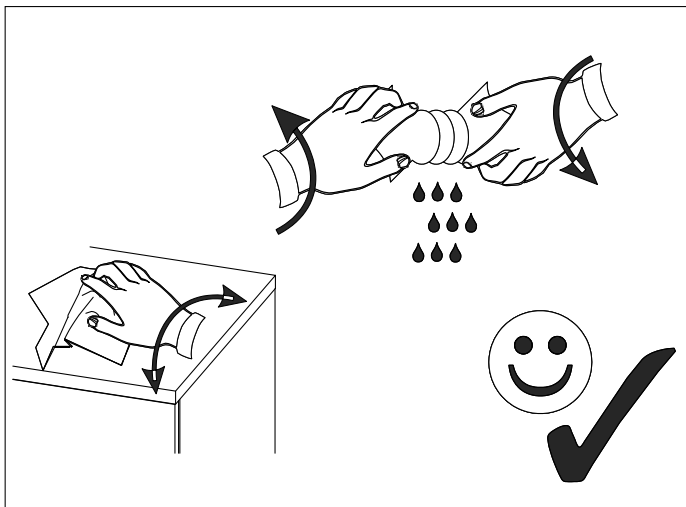
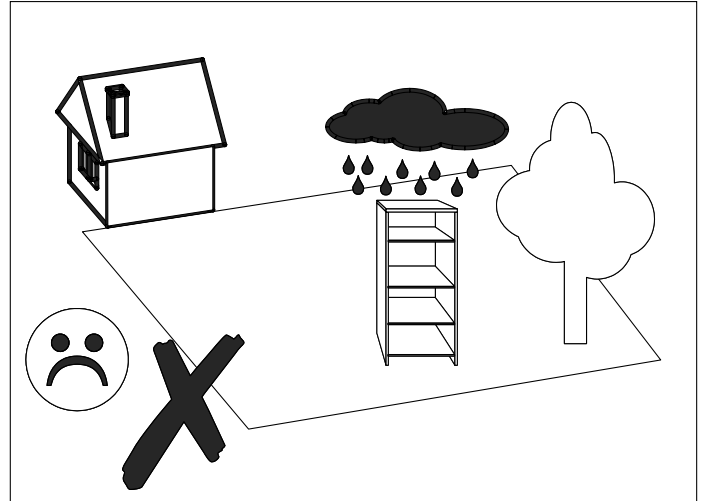
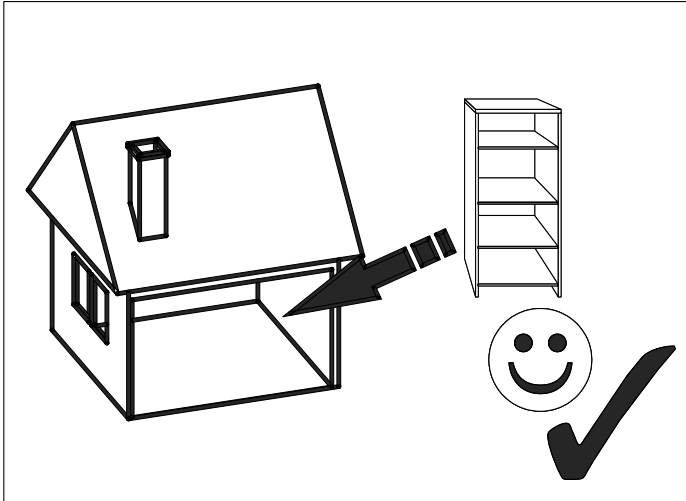

1

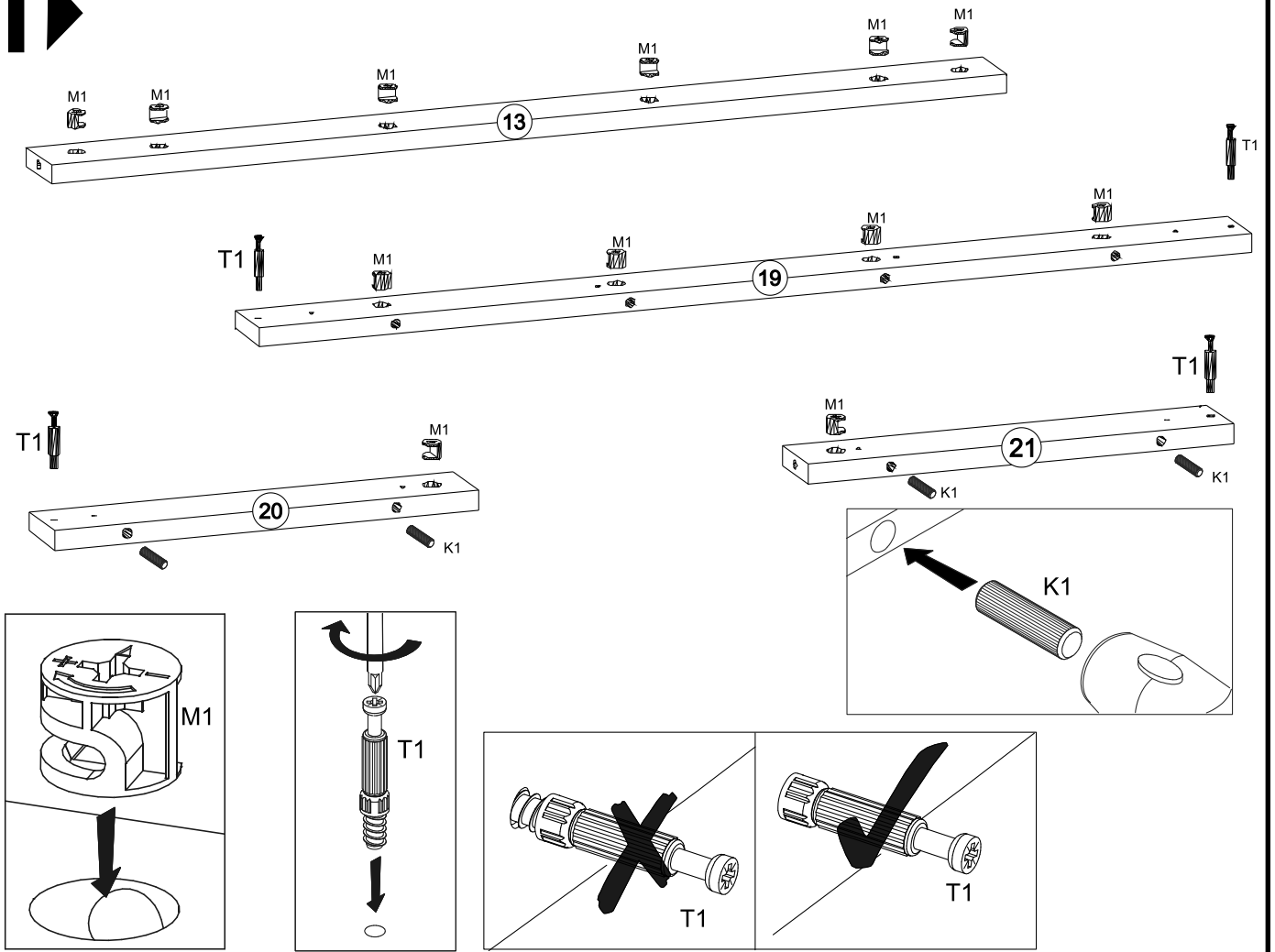

2

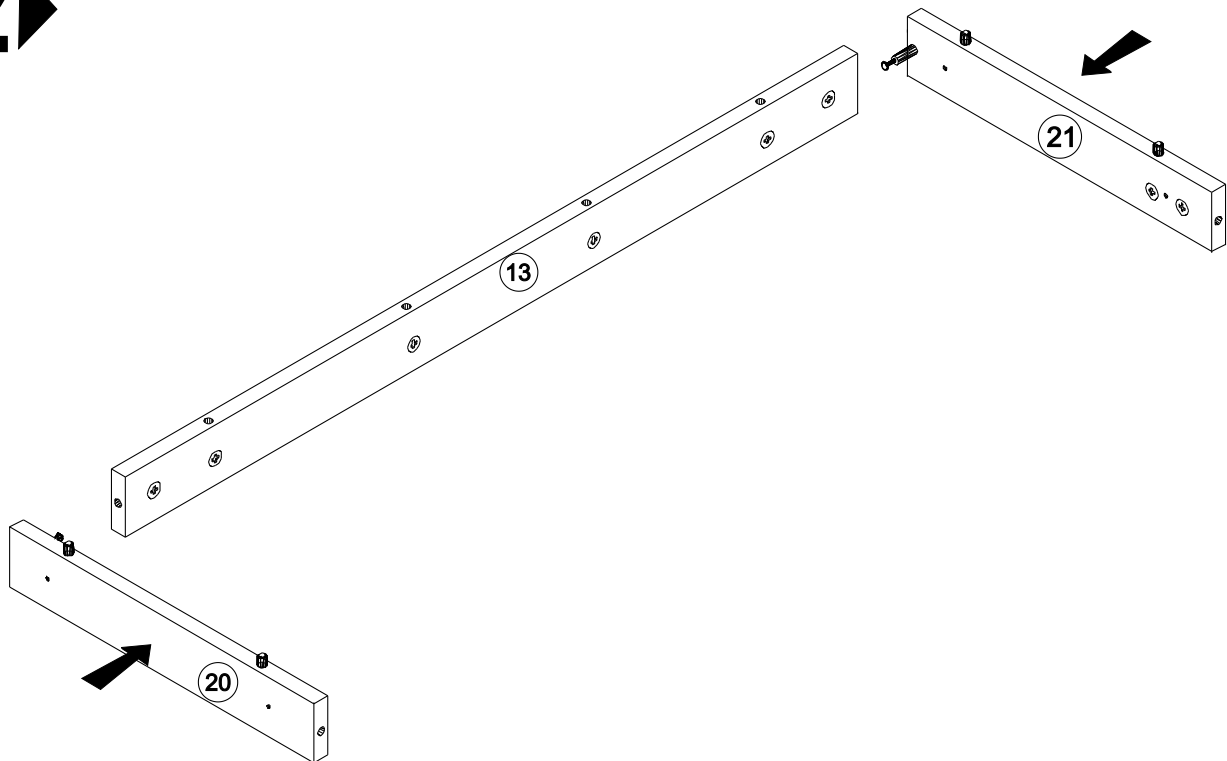

3 ➔

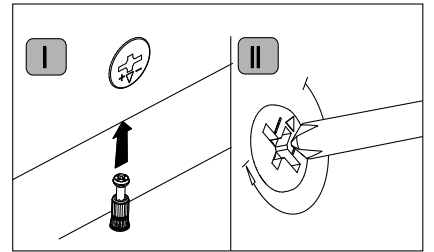
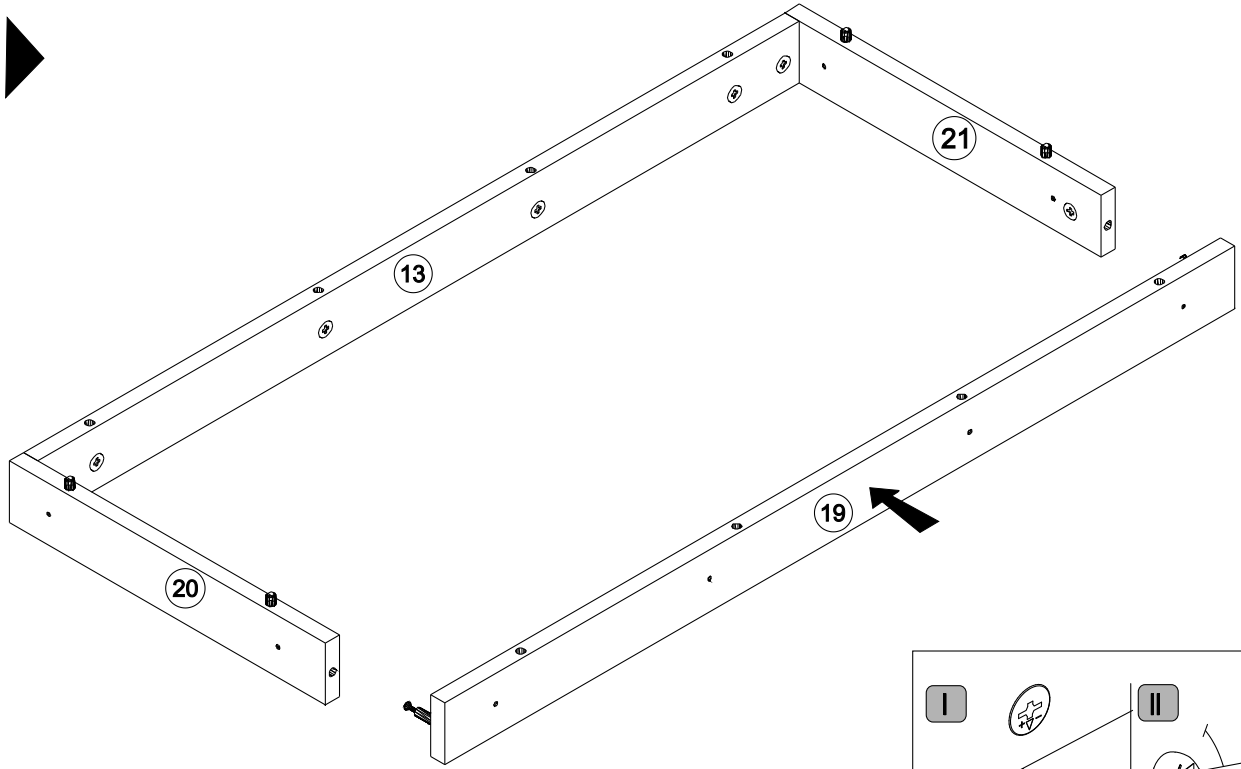

4 ➔

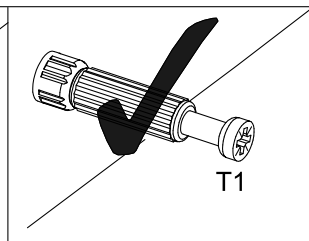
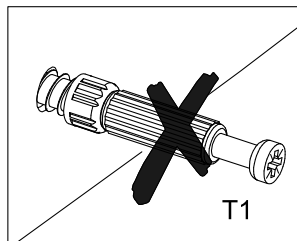
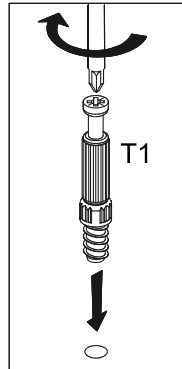
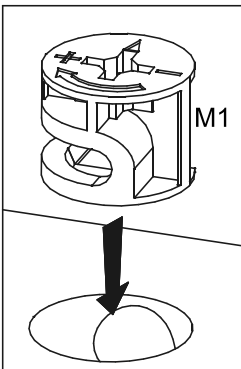
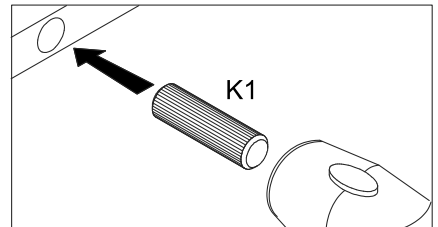
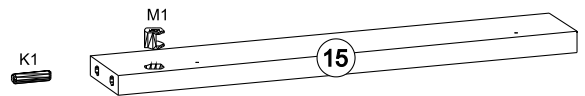
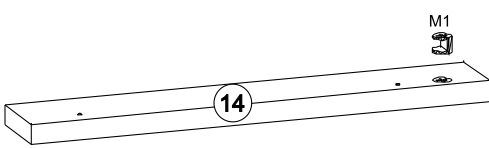
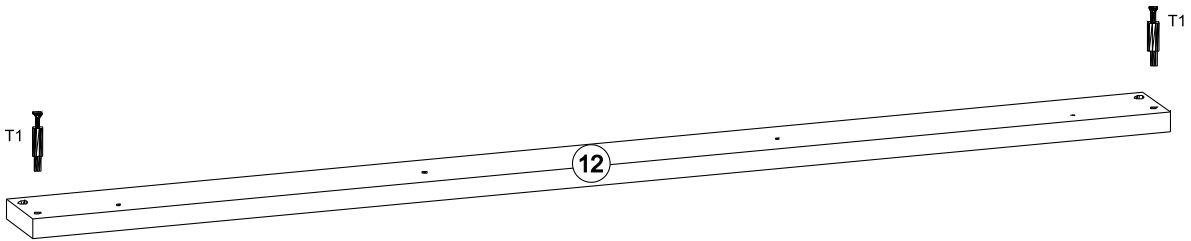

5

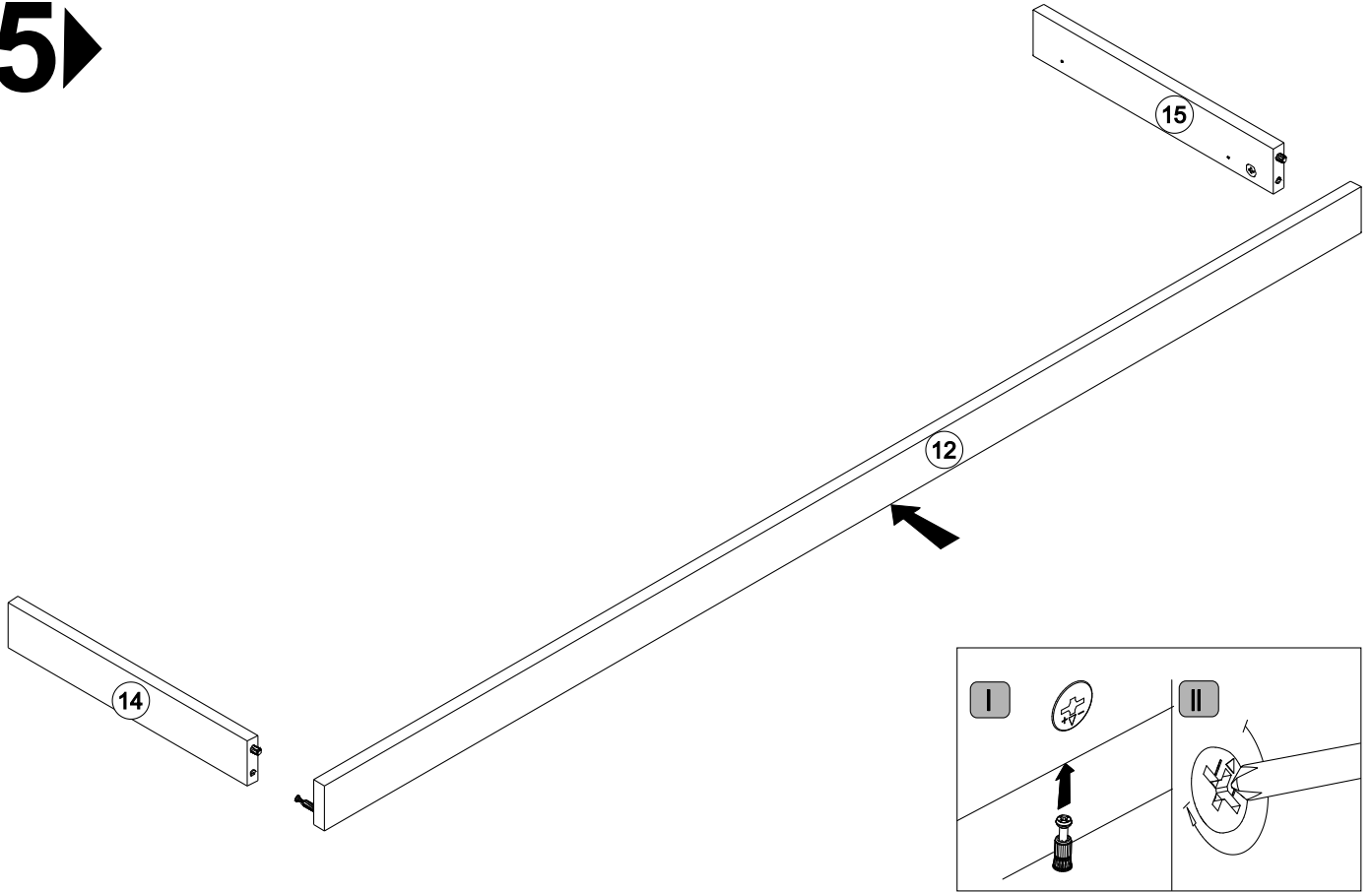

6

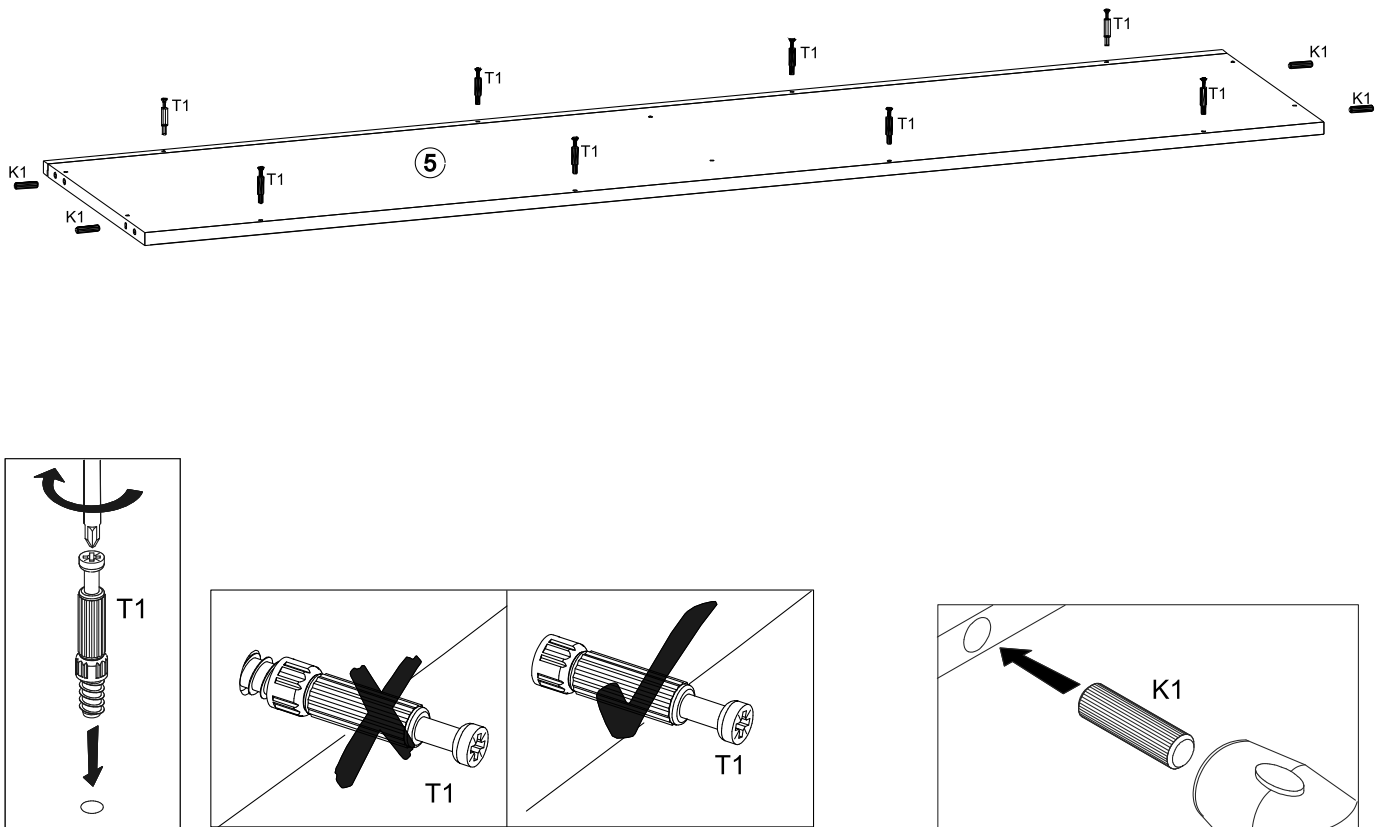

7

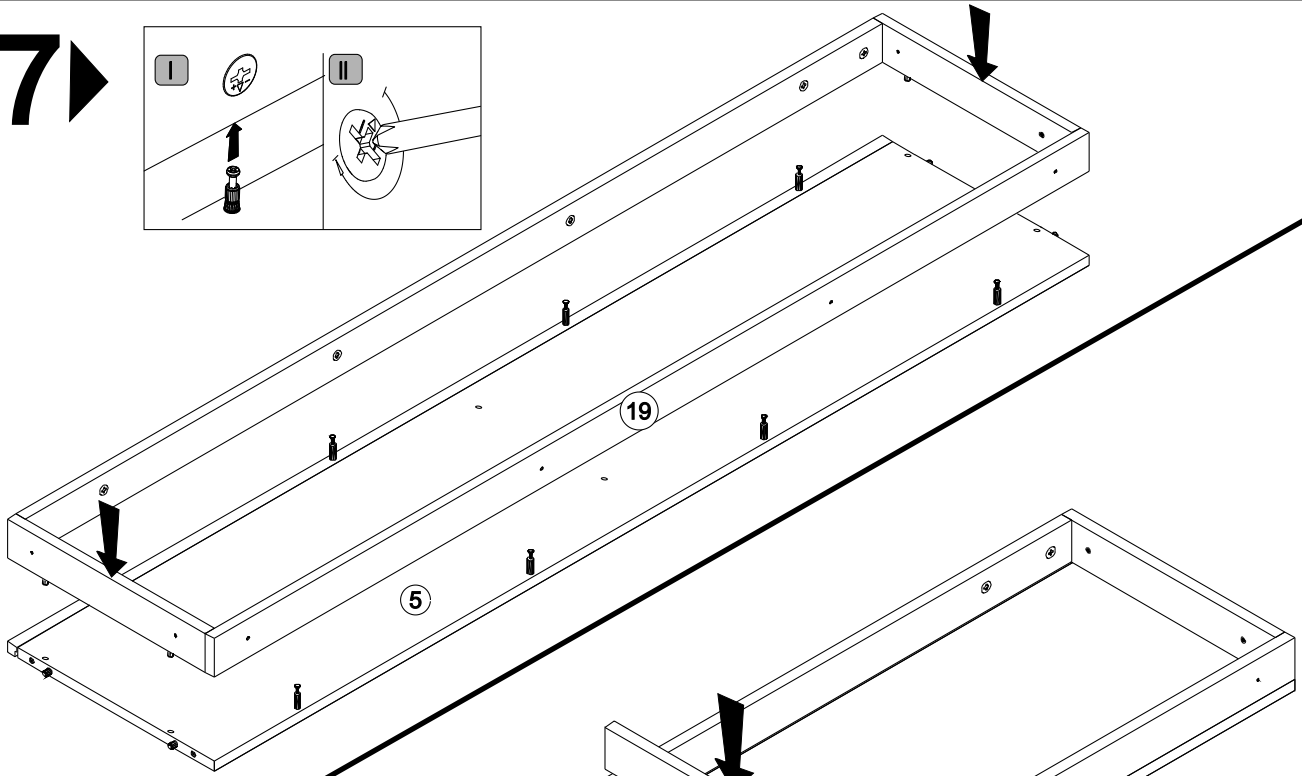
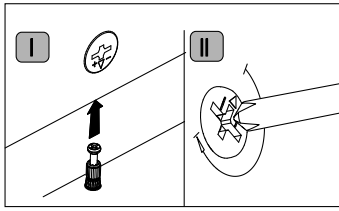

8

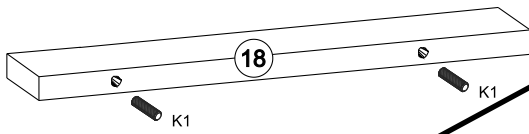
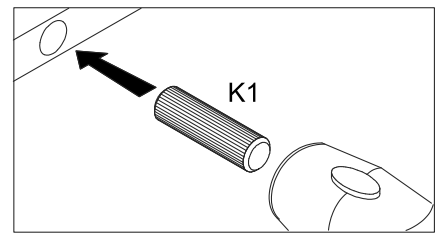
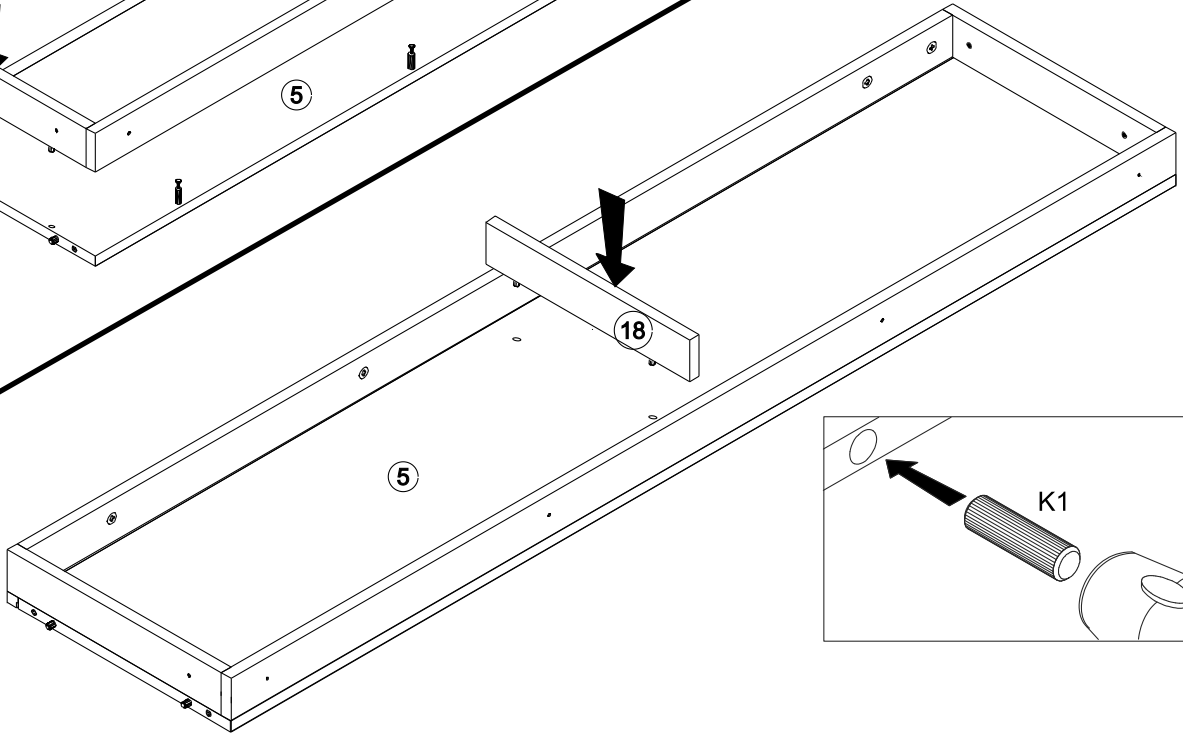

9

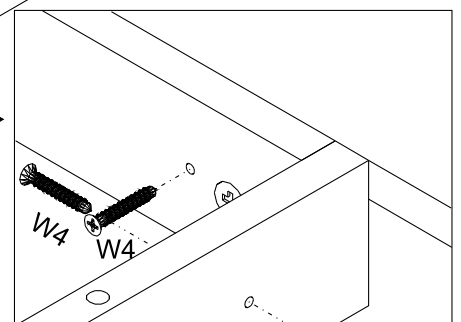
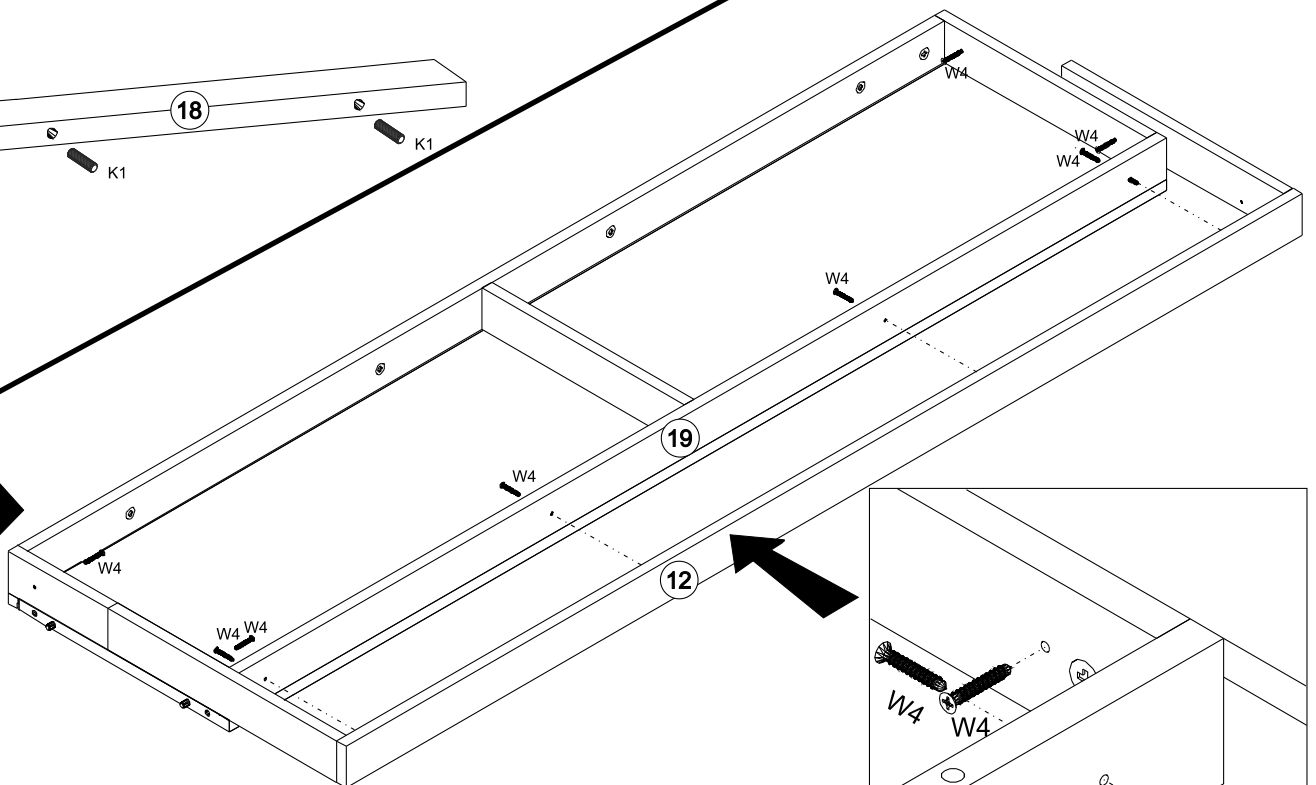

10 ▶

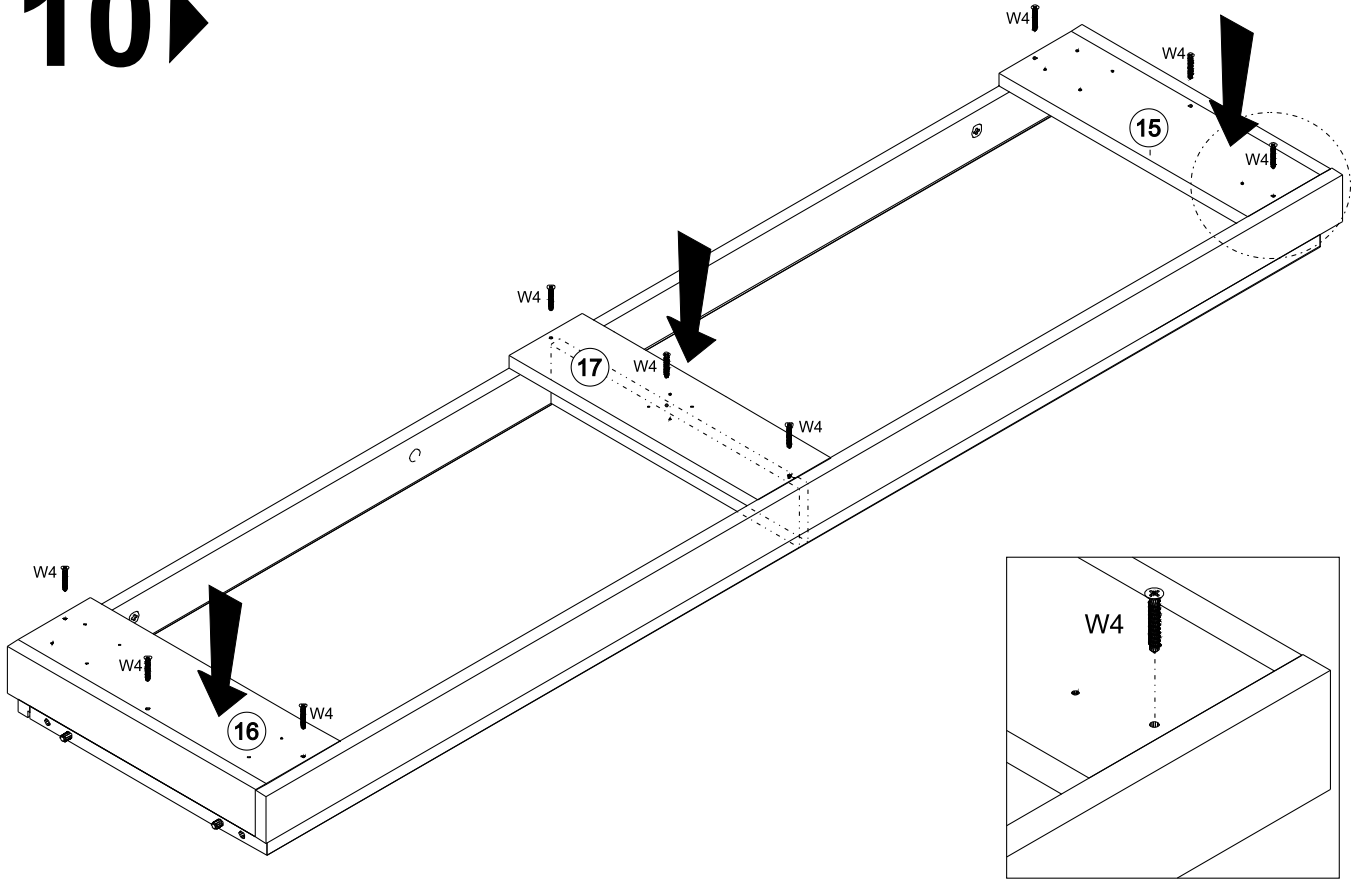

11 ▶

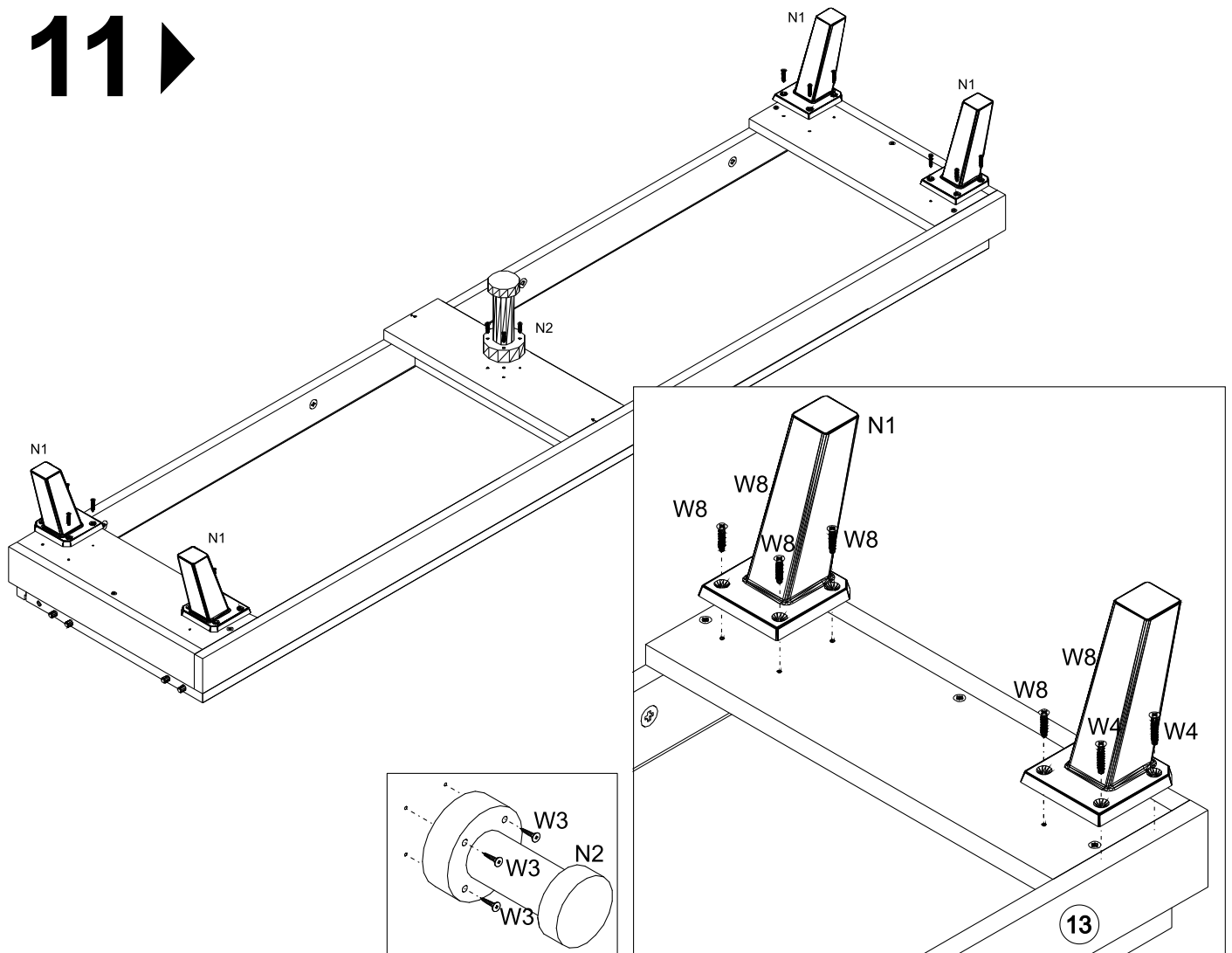

12▶

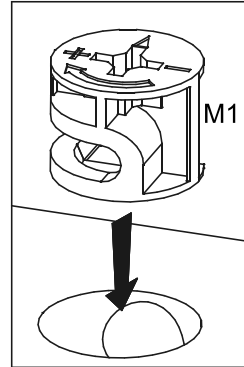
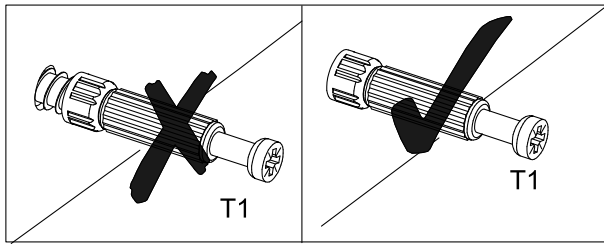
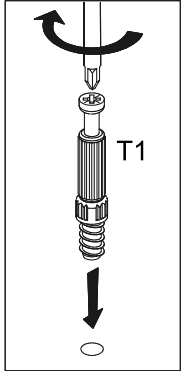
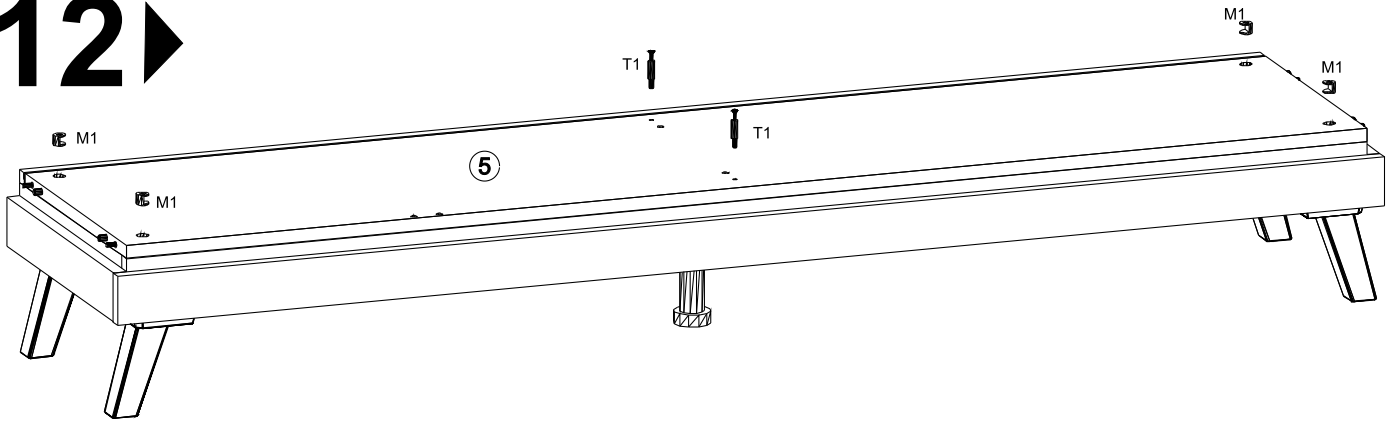

13▶

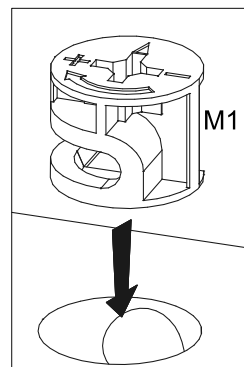
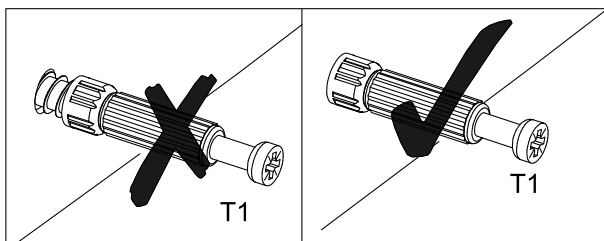
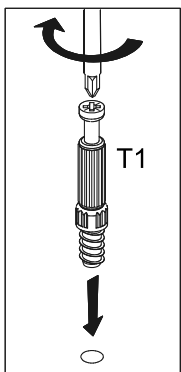
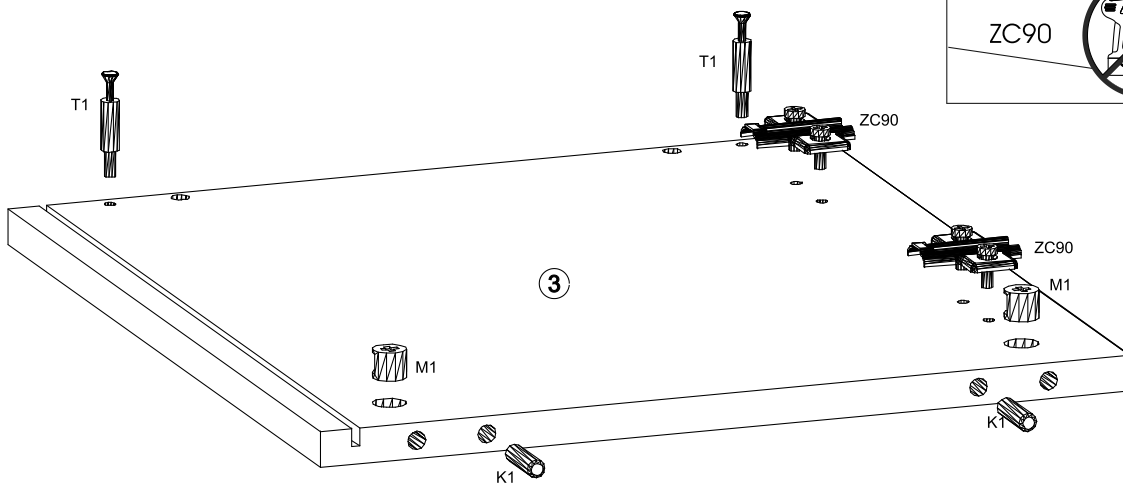
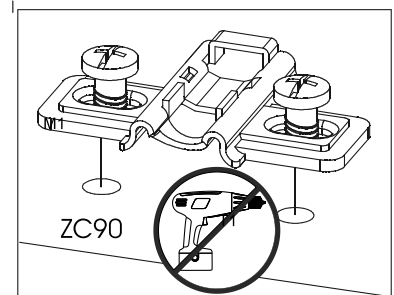
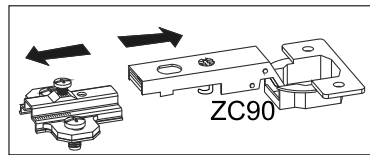

14

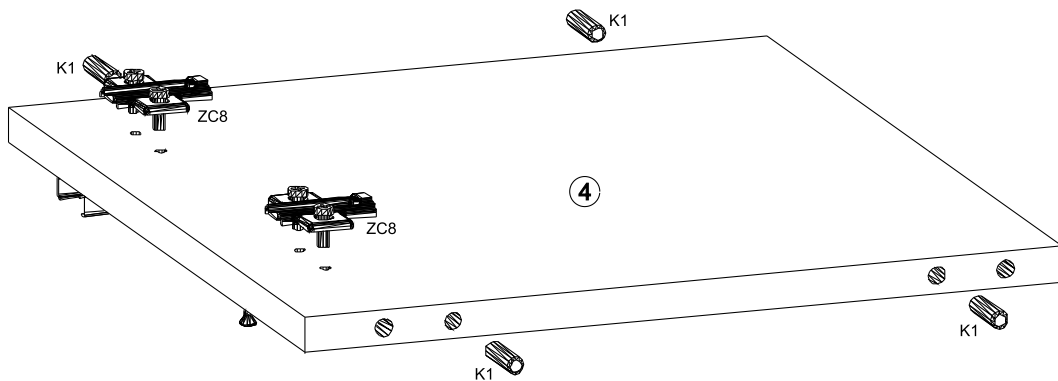
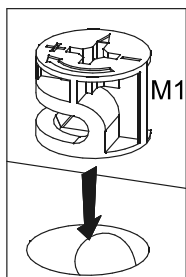
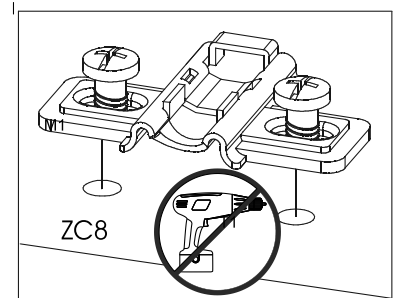
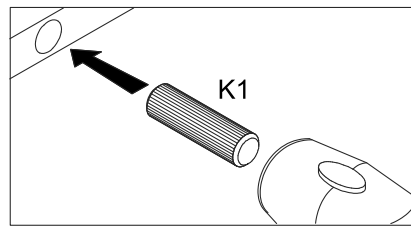
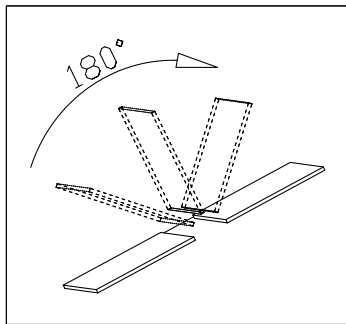
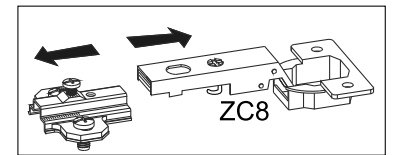
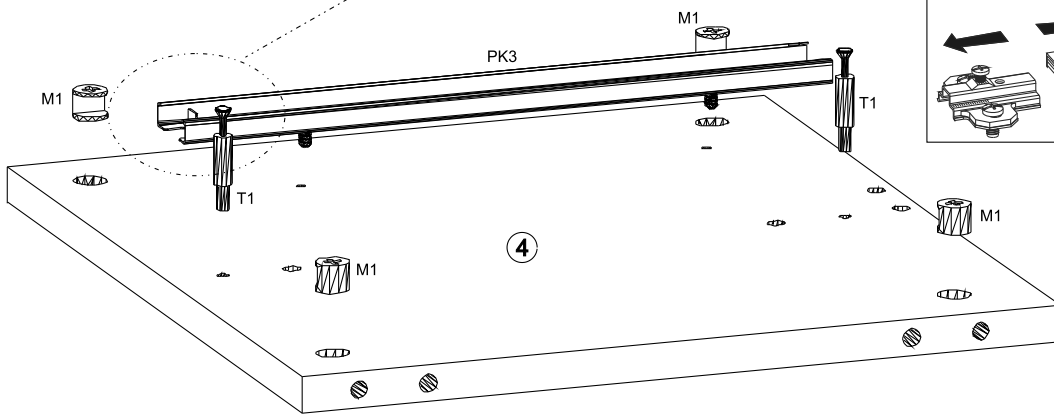
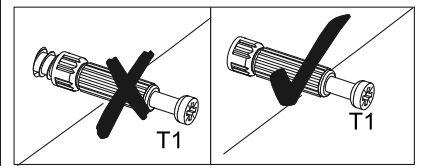
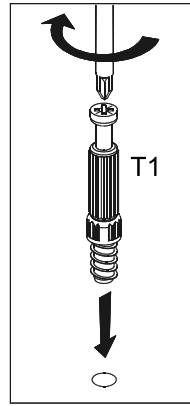
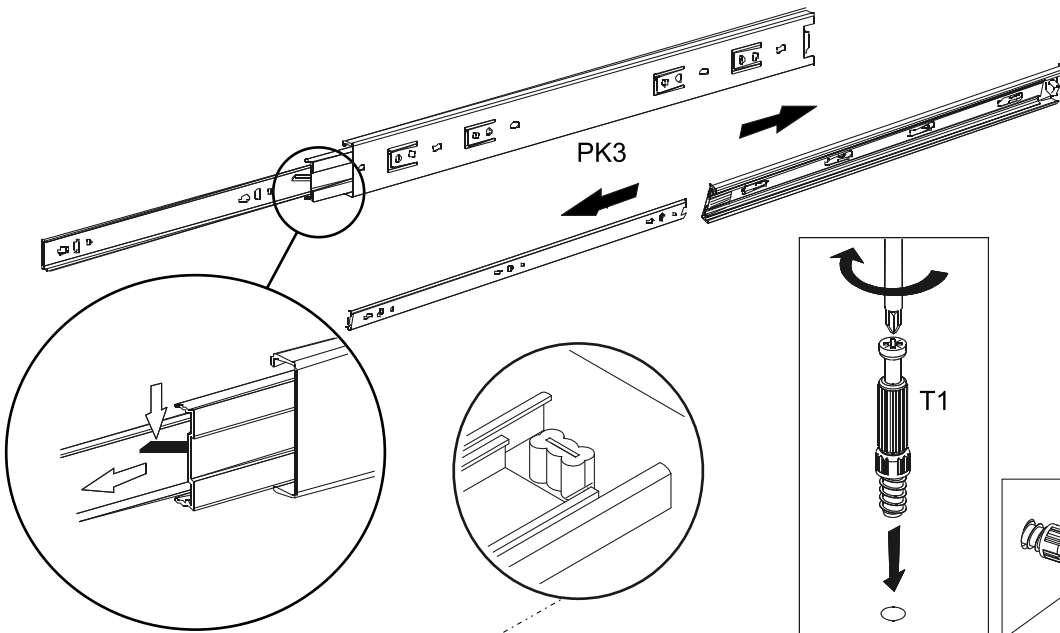
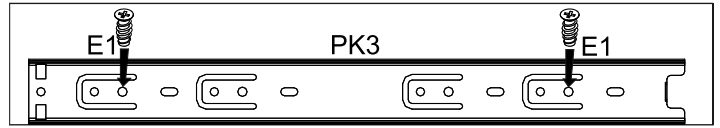

15 ▶

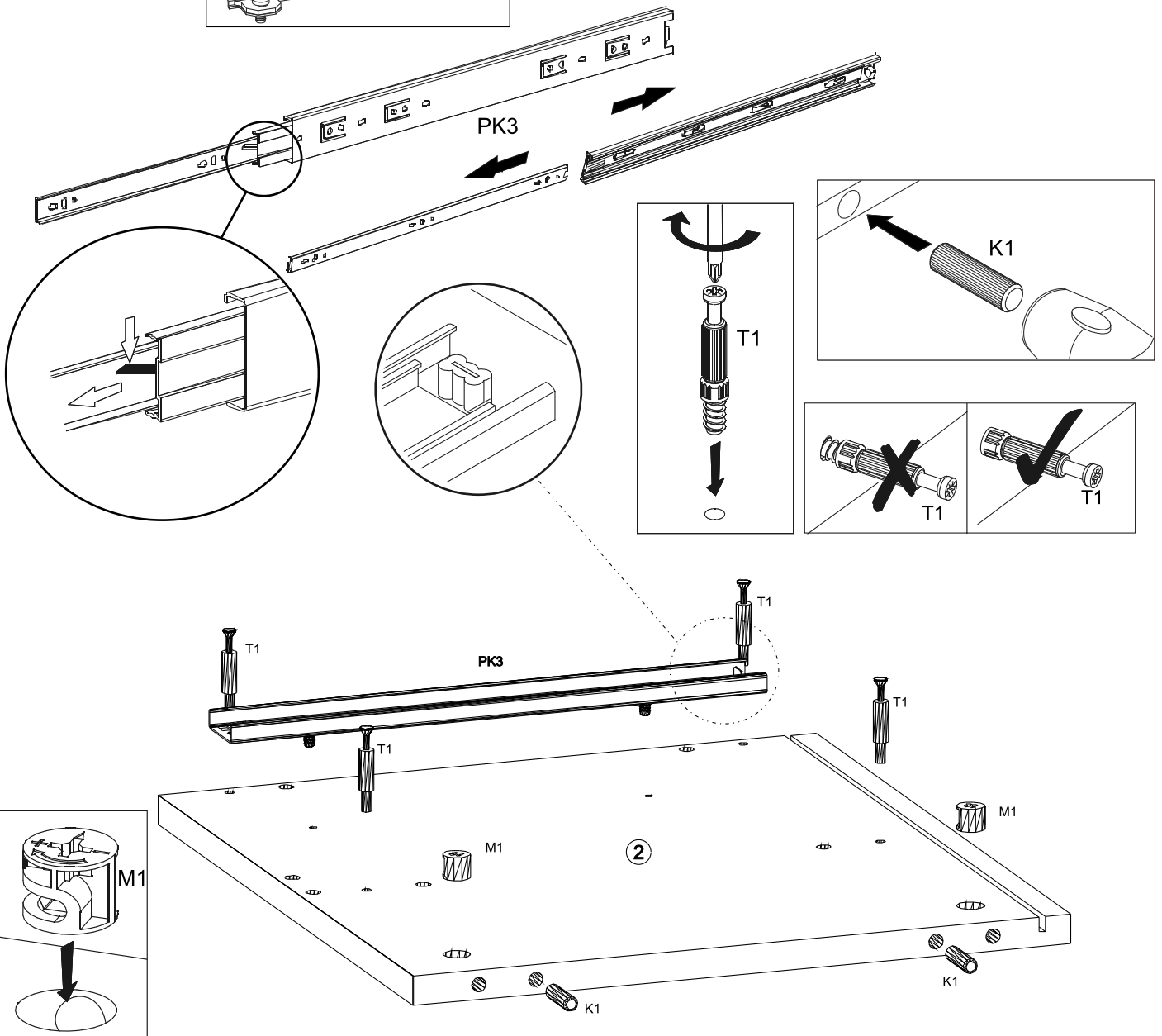
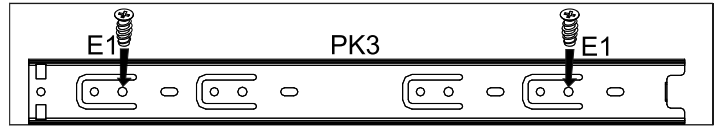
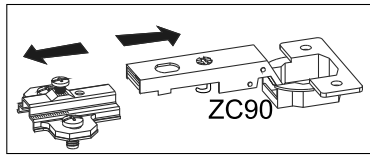

16 ▶

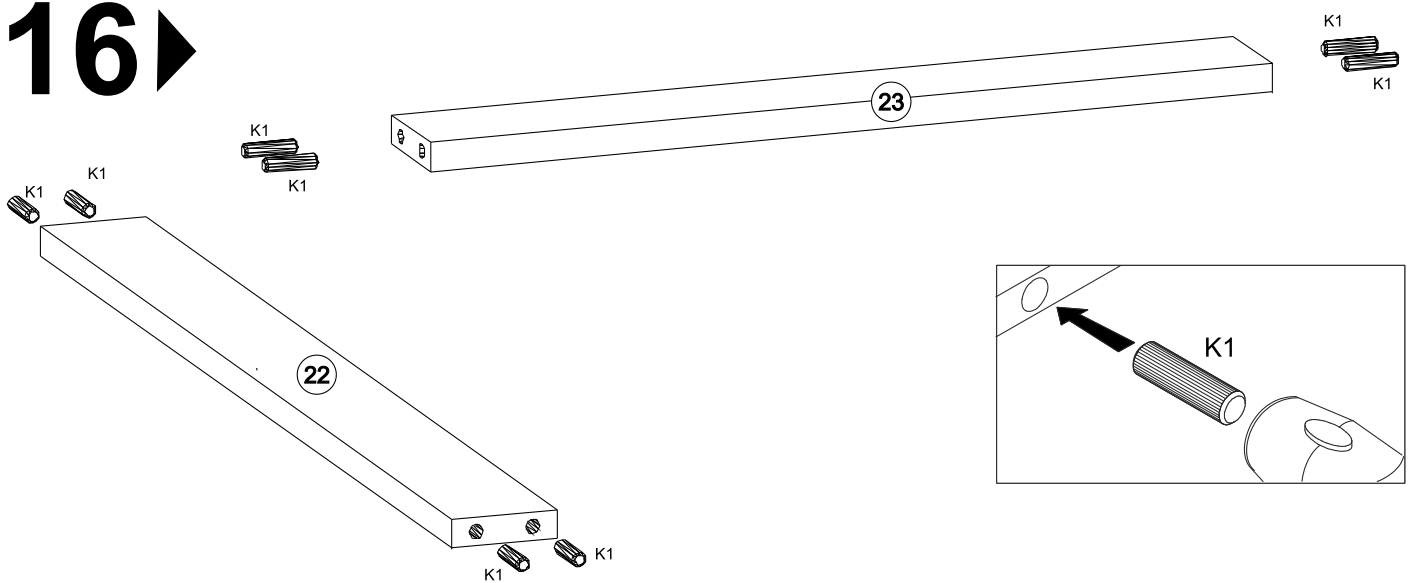

17▶

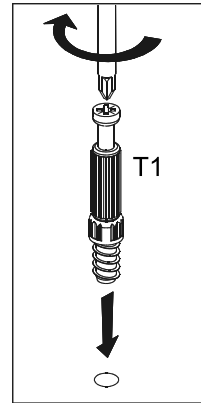
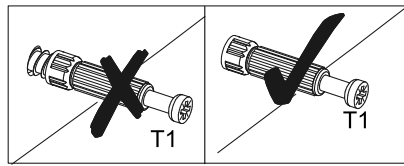
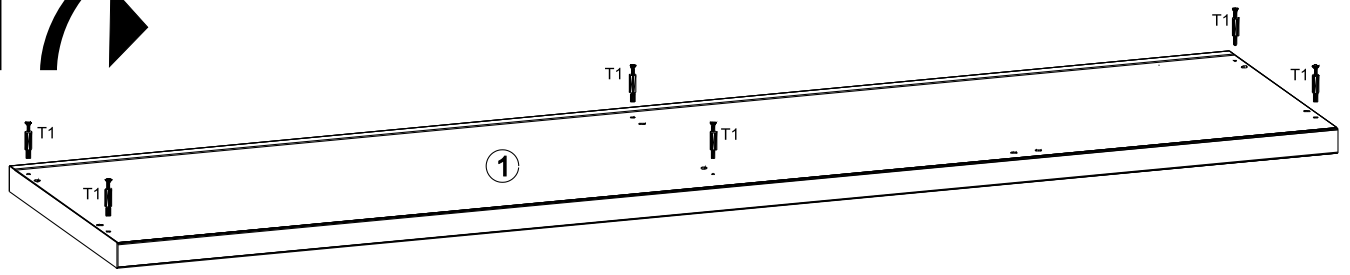

18▶

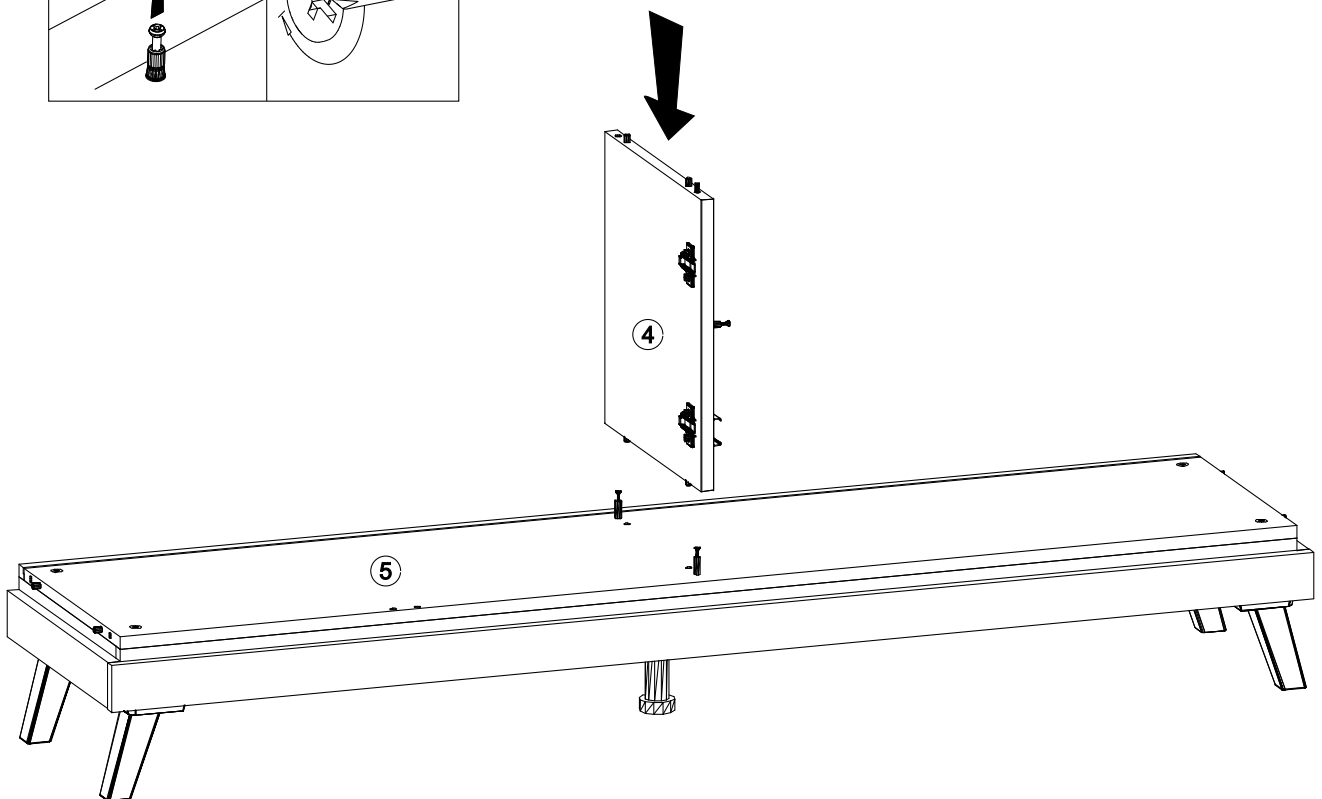
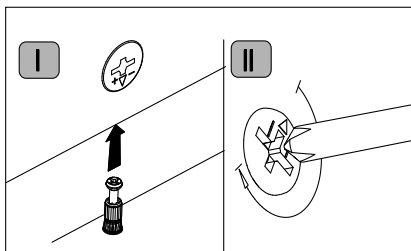

19 ▶

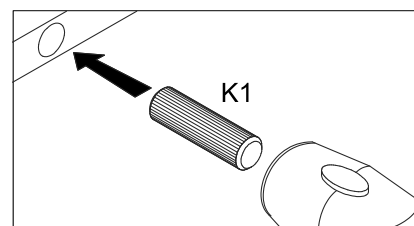
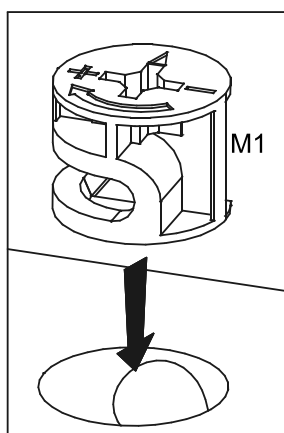
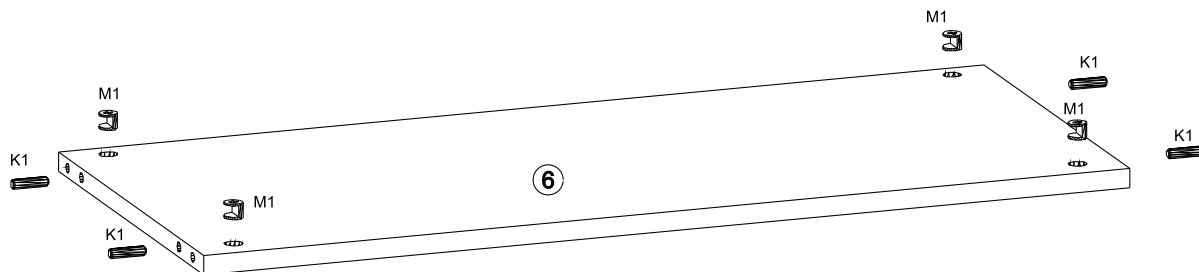

20 ▶

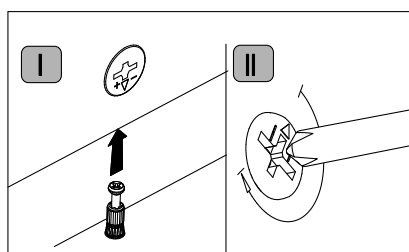
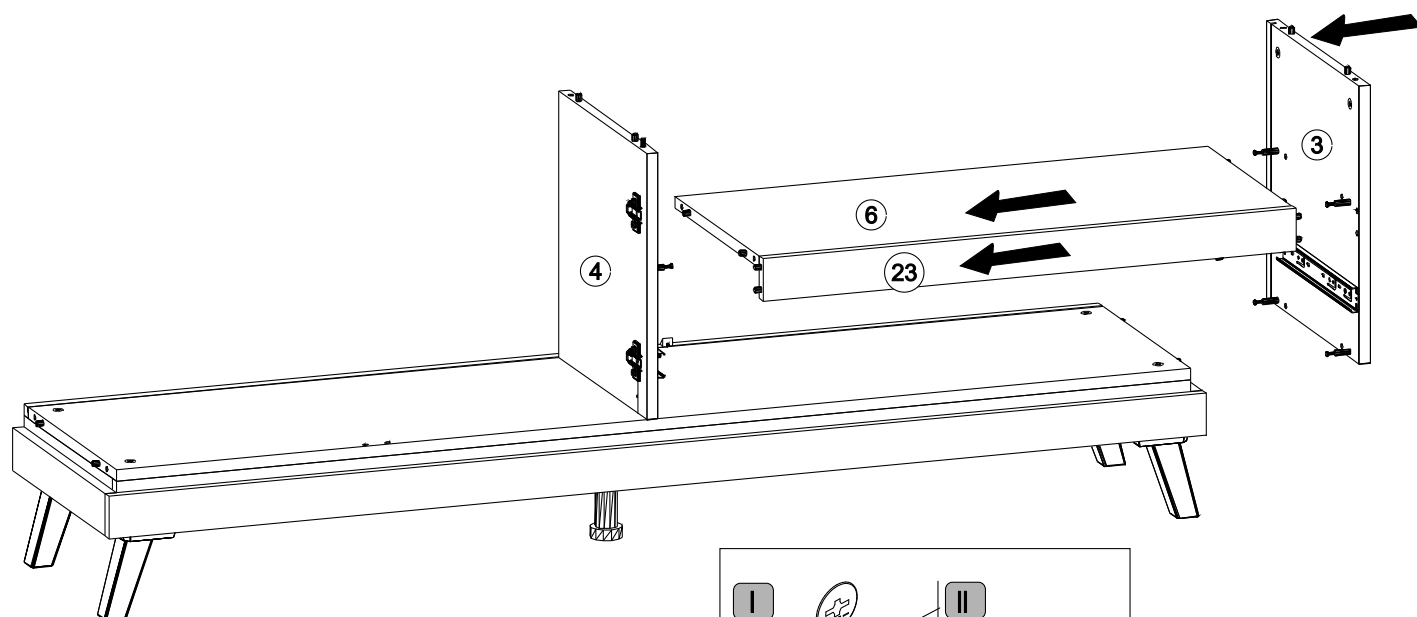

21 ▶

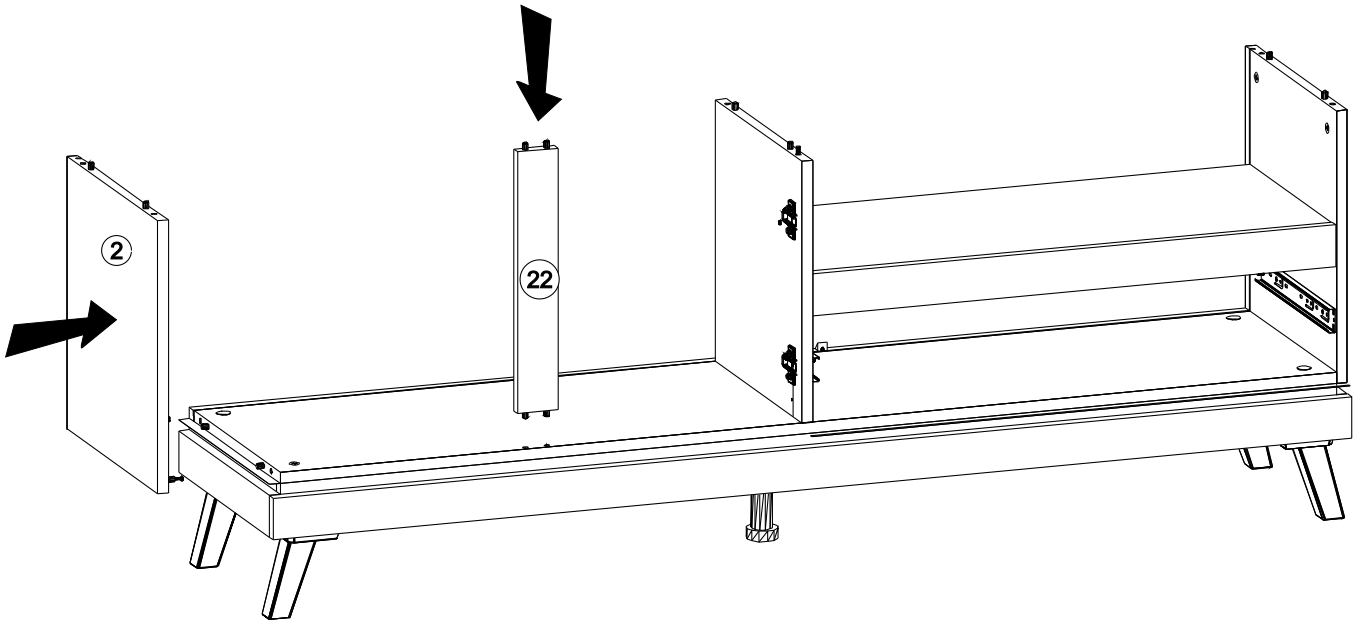
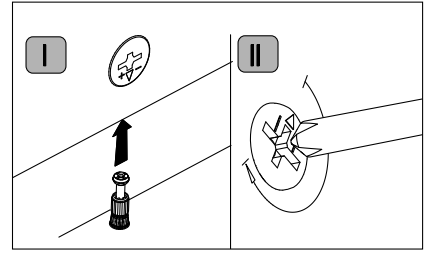

22 ▶

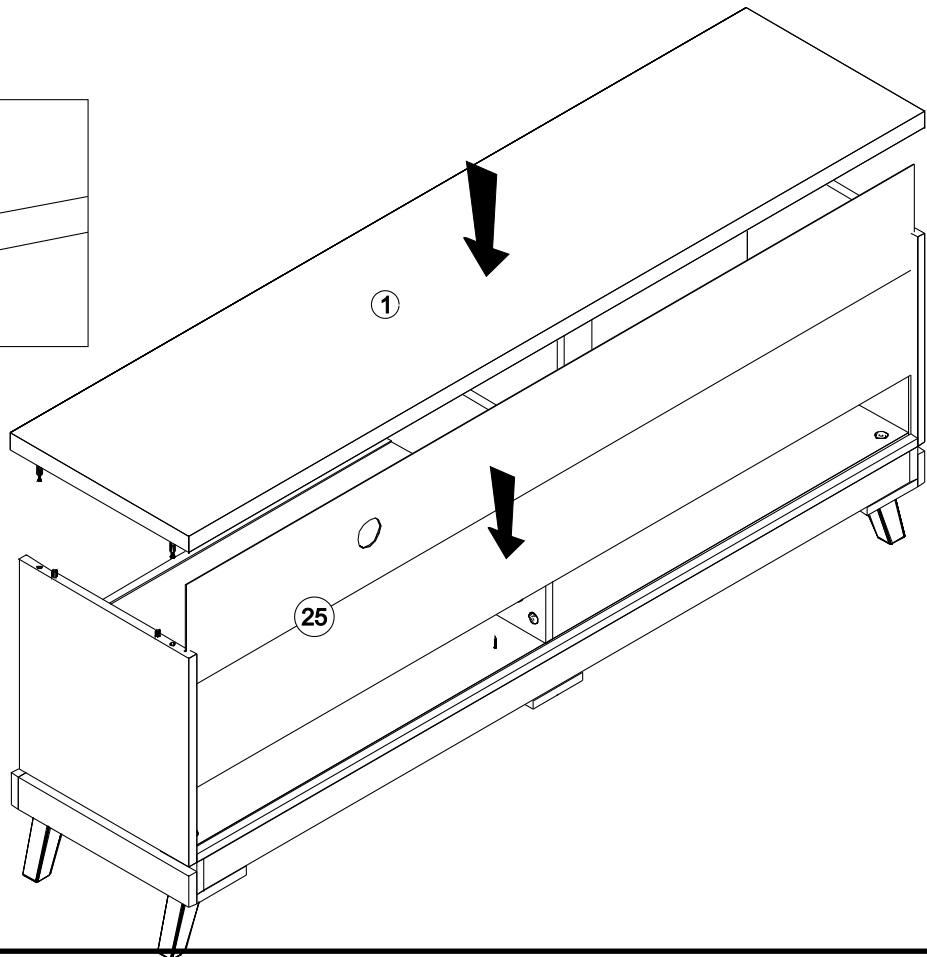
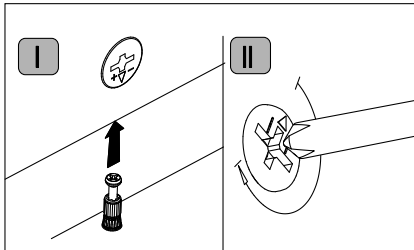

23 ▶

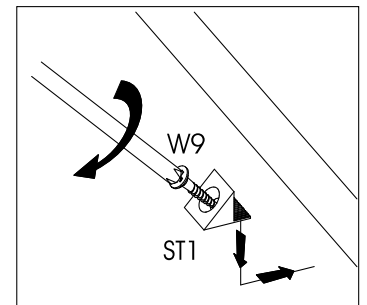
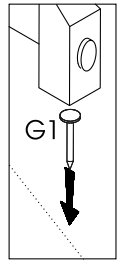
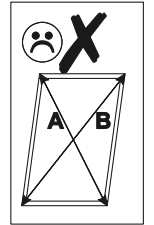
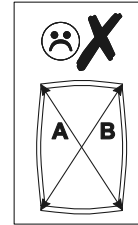
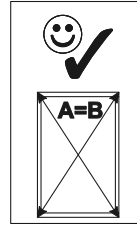
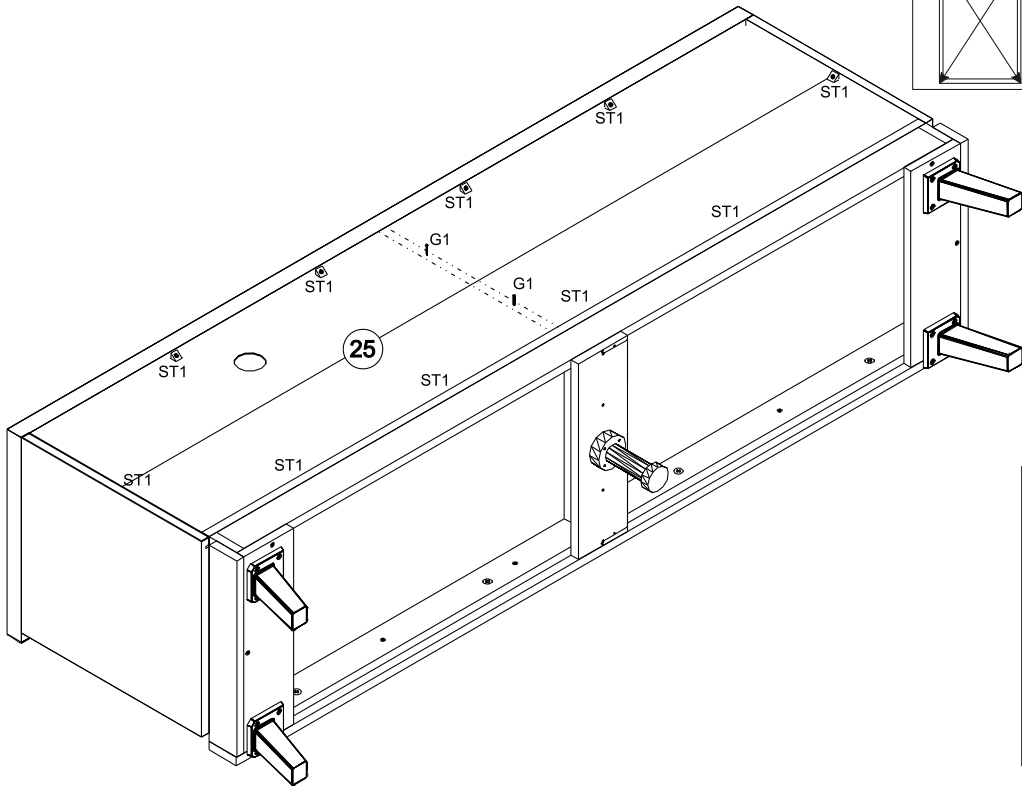

24 ▶

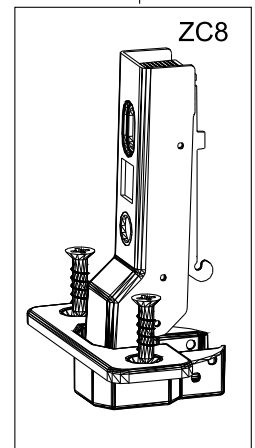
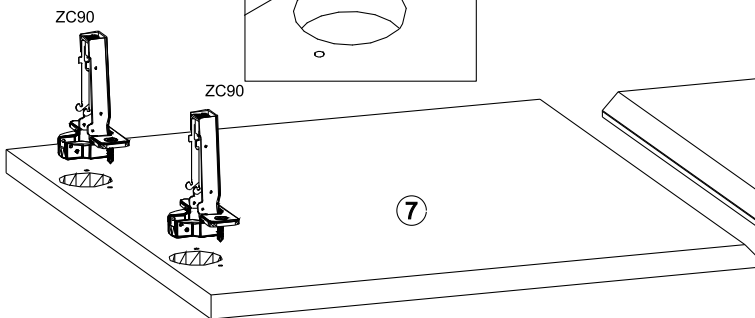
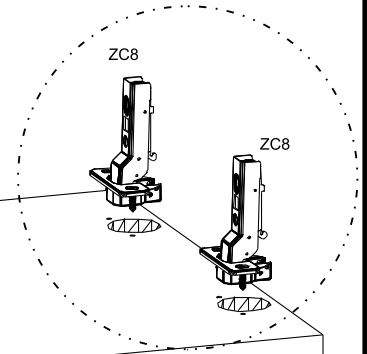
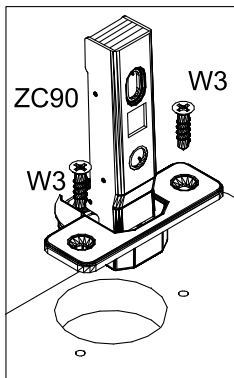

25 ▶

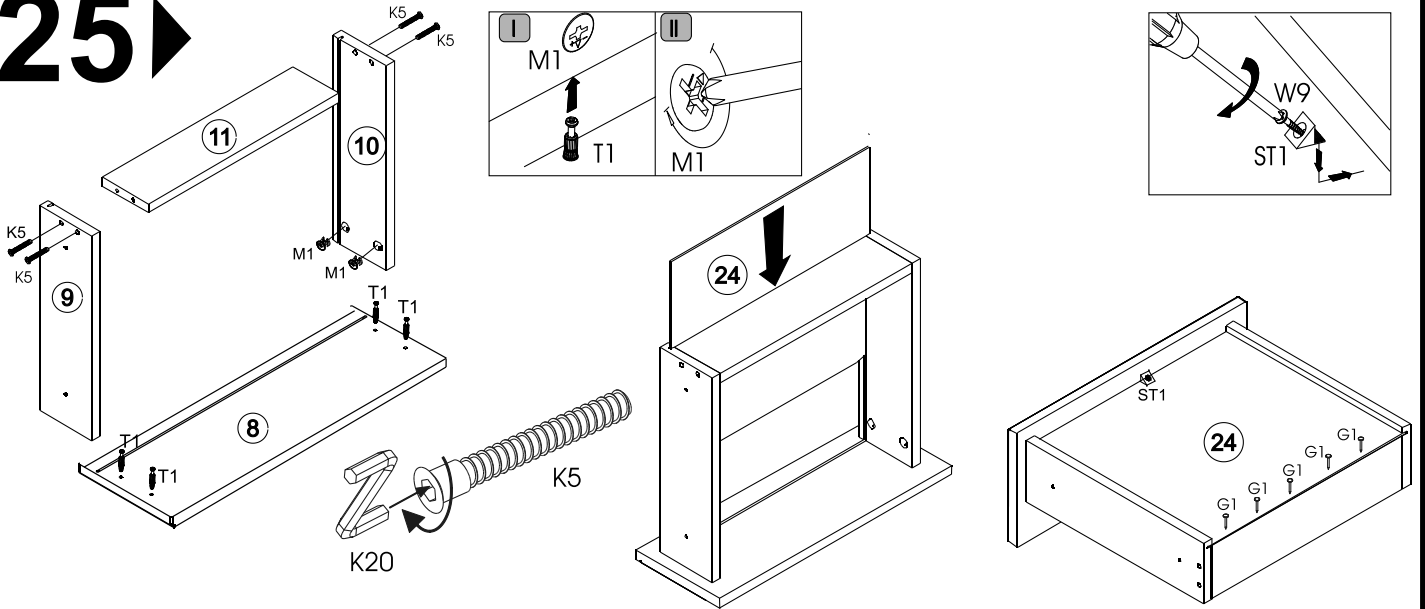

26 ▶

